

Career and Academic Planning Guide

2003 – 2004

Grades 8 – 12

Fayetteville Public Schools

GENERAL INFORMATION

Advanced Placement: Information on the Advanced Placement program and fees for the examinations may be found in Appendix A.

Apprenticeship: Youth Apprenticeship is a different approach to education. The objective of Apprenticeship is to broaden the educational, career, and economic opportunities for all youth through partnerships among businesses, schools, community-based organizations as well as state and local governments. Enrollment in an Apprenticeship provides an opportunity for students to explore the world of work and receive school credit as well as receiving payment for their jobs. Students must enroll in the appropriate class to be eligible for Apprenticeship opportunities. Information regarding Youth Apprenticeship may be found in Appendix A-5.

Arkansas Academic Challenge Scholarship Program: The Arkansas Academic Challenge Scholarship Program provides scholarships in the amount of \$1500 or tuition, whichever is less, to Arkansas high school students who qualify. This scholarship is currently being assessed for continuation by the Arkansas State Legislature. Consult your counselor on the status of this scholarship and the qualifications.

Attendance: All students under the age of 18 must be enrolled in school and be in regular attendance. Any student who does not comply with the district attendance policy #5113, AR 5113.1 (see Student Handbook) must be reported to the Prosecuting Attorney for the City of Fayetteville and the Arkansas Department of Finance and Administration in accordance with state law. The Department of Finance and Administration is required to revoke the driver's license of any student who is reported for non-attendance. A minimum number of periods of required instruction in which students must be enrolled will be established by the administration. During pre-registration and Career and Academic Planning (CAP) conferences, students will be informed of the number of required classes necessary for the coming year.

College and Career Connections: Earn College Credit while in High School! Students who are enrolled or have taken certain high school courses (Technical Advanced Placement courses) can earn college credit, "free of charge", and begin working toward an Associate of Applied Science Degree (A.A.S.) at NorthWest Arkansas Community College (NWACC) in Bentonville, Arkansas or a Certificate Program at Northwest Technical Institute (NTI) in Springdale, Arkansas. You must earn an "A" or "B" in the course to receive the college credit and enroll at NWACC or NTI within 18 months after high school graduation. See Appendix A-4 for more information.

Concurrent Enrollment: Outstanding high school students (grades 9-12) who wish to take selected University of Arkansas courses while enrolled in high school may be admitted concurrently if specific requirements have been met and if approval is granted by the UA Campus Faculty Committee on Admissions and Transfer of Credit. The requirements are as follows:

- The student must submit standardized test scores (ACT, SAT, or PSAT) at the 80th percentile on national norms in the subject matter area of the course(s) in which the student intends to enroll. (Note: ACT national norms at the 80th percentile are as follows: Composite 25, English 25, Mathematics 25, Reading 26, Science Reasoning 25.)
- The student must have either a 3.5 GPA in high school courses in the subject matter in which he/she wishes to enroll OR an overall GPA of 3.5.
- The student must submit a letter of recommendation from the high school principal and a personal statement of intent, indicating the subject matter area in which the student plans to enroll.
- Student should apply no later than one month prior to the term in which they wish to enroll.

Arkansas State law allows high school juniors and seniors to receive high school credit, as well as college credit, for enrollment in college courses. Please consult your high school counselor and the college admissions office for further information.

Step Ahead Enrollment: The Fayetteville School District allows Step Ahead enrollment in conjunction with Northwest Arkansas Community College. Fayetteville High School offers the following semester courses at the high school campus when enrollment indicates the need:

EAST CAMPUS

| | | |
|-----------------------------------|----------------|---|
| Western Civilization WCIV 1003 | fall | elective credit at FHS and three hours western civilization college credit |
| Western Civilization WCIV 1013 | spring | elective credit at FHS and three hours western civilization college credit |
| College Algebra 1204 | fall or spring | elective credit at FHS 4 college hours |
| Finite Math 2053 | spring | elective credit at FHS 3 college hours |

WEST CAMPUS

| | | |
|-------------------------------------|----------------|--|
| English Composition I ENGL 1013 | fall or spring | elective credit at FHS and three hours English college credit |
| English Composition II ENGL 1023 | fall or spring | elective credit at FHS and three hours English college credit |
| Biology BIOL 1544 | fall | elective credit at FHS and three hours biology college credit |

To enroll in a Step Ahead class, a student must meet the following requirements:

1. Be enrolled in grades 11-12.
2. Have a 3.0 or higher grade point average on a 4.0 grading system.
3. Pay tuition of approximately \$46 per credit hour.
4. Be responsible for purchasing his own text. (The bookstore at NWACC sells and buys texts, new and used.)
5. Have appropriate placement test scores.
6. Have current measles and rubella immunizations form on file at the high school.

The Compass is given at NWACC. Call 636-9222, ext 2018 for a testing appointment. There is a \$5 testing fee. There may be additional test score requirements as indicated below.

- To enroll in Western Civilization, Biology, English Comp I, or English Comp II, a student must have a minimum test score of 19 ACT reading, or 470 on SAT reading, or 82 on Compass Reading.
- To enroll in College Algebra a student must have one of the following minimum test scores: 19 ACT math, 460 on SAT math, or 40 in Numerical Skills position and 43 in the Elementary Algebra and Intermediate Algebra portion of ASSET or 39 in the Pre-Algebra and 65 in Algebra portion of the Compass.
- To enroll in Finite Math a student must meet have completed College Algebra with a grade of “C” or better, or a minimum score of 24 on ACT math.

To receive college credit, a student must have a “C” average or higher for the semester grade in the course. If the student fails to have at least a “C” semester grade in a Step Ahead course, the student is not eligible to take another Step Ahead course.

College credit in this program is accepted at the University of Arkansas and every university in the state. Students who plan to attend a university outside the state are encouraged to check with their prospective university’s registrar to determine if they will accept the credits.

Early Graduation for East Campus only: Students who wish to be considered a candidate for graduation prior to completion of eight (8) semesters of high school attendance must file a written request with the East Campus principal no later than one full year before the selected graduation date. If a student is a minor, he/she must also provide written permission to accelerate course work from his/her parent/guardian. Approval for early graduation is made by the principal who will consult with the candidate's counselor, parent/guardian and teachers.

These are the guidelines for the early graduation process.

- Approval/disapproval for enrollment in classes for acceleration will be based upon class size and availability. Regular students will not be bumped in order to make room for student requesting early graduation.
- The candidate's cumulative GPA must be 3.0 or higher at the time of approval.
- Elective credits may be completed in summer school but not core classes and not more than 1.5 units.
- Alternative learning (summer school, UA correspondence, independent studies) may not exceed 1.5 units of pre-approved coursework.
- A student may take summer school for remediation of core courses.
- Consideration may be given to students with special needs.
- The student must have an 85% accumulative attendance record.
- All course work must be completed before graduation.
- No student can receive early graduation with less than 6 semesters of high school attendance.

This form is effective as of October 16, 2001.

East Campus-School Schedule and Class Requirements: At East Campus seven hours of academic courses are offered for all students, designated zero through sixth period. Zero hour represents an "early start" option. Students who select zero hour class option must be responsible for their own transportation to school.

Juniors and sophomores must enroll in six consecutive classes and seniors must enroll in five consecutive classes. No student will be required to enroll in seven periods.



Counselors-The Role of the Professional School Counselor: The professional school counselor is a certified educator who addresses the needs of students comprehensively through the implementation of a developmental school counseling program. School counselors work with all students, including those who are considered “at risk” and those with special needs. They are specialists in human behavior and relationships who provide assistance to students through four primary interventions: counseling (individual and group); large group guidance; consultation; and coordination.

Counseling is a confidential relationship in which the counselor meets with students individually and in small groups to help them resolve or cope constructively with their problems and developmental concerns.

Large group guidance a planned, developmental, program of guidance activities designed to foster students’ academic career, and personal/social development. It is provided for all students through a collaborative effort by counselors and teachers.

Consultation is a collaborative partnership in which the counselor works with parents, teachers, administrators, school psychologists, social workers, visiting teachers, medical professionals, and community health personnel in order to plan and implement strategies to help students be successful in the education system.

Coordination is a leadership process in which the counselor helps organize, manage, and evaluate the school counseling program. The counselor assists parents in obtaining needed services for their children through a referral and follow-up process and serves as liaison between the school and community agencies so that they may collaborate in efforts to help students.

Professional school counselors are responsible for developing comprehensive school counseling programs that promote and enhance student learning. By providing interventions within a comprehensive program, school counselors focus their skills, time, and energies on direct services to students, staff, and families.

Above all, school counselors are student advocates who work cooperatively with other individuals and organizations to promote the development of children, youth, and families in their communities. School counselors, as members of the educational team, consult and collaborate with teachers, administrators, and families to assist students to be successful academically, vocationally, and personally. They work on behalf of students and their families to insure that all school programs facilitate the educational process and offer the opportunity for school success for each student. School counselors are an integral part of all school efforts to insure a safe learning environment for all members of the school community.

Fayetteville Adult Education Program: Students who are eighteen years of age or older may enroll in enrichment classes or enter a GED program. Students under the age of eighteen must have approval of the principal of their home school before being admitted to the Adult Education program.

Foreign Exchange Students: A student transferring from another country shall be expected to meet all FHS graduation requirements in order to receive a diploma. Where questions exist about the content or comparability of classes taken in another country, the student must provide documentation to assist the principal in converting courses to Carnegie units so that course credit may be awarded. The final decision regarding course credit rests with the principal. Only two semesters of English can be taken a year to meet graduation requirements. One semester of Government and two semesters of American History are also required. Exchange students and other foreign students who do not meet graduation requirements may receive a certificate of attendance.

GED Program: Students 16 or 17 years of age may enroll in a GED program at West Campus with the approval of the principal. A student and his/her parent must meet with the principal, evaluate the student’s academic progress, and determine if this alternative program is the proper placement. The final decision rests with the West Campus principal.

Homebound: Homebound instruction is provided to students who cannot attend school due to a long term illness. Applications for homebound instruction are available in the assistant superintendent's office. Credits earned through approved homebound instruction will count towards graduation.

Independent Study: Independent study programs are utilized mainly for remediation only. Students will be limited to **one and a half units of independent study credit**. All independent study courses must have the prior approval of the principal. Students who desire more information may speak to a counselor. There may be a fee for independent study courses.

Minimum Core for Higher Education: For unconditional admissions to any public two-year or four-year institution of higher education in Arkansas, students must successfully complete a core curriculum established by the Arkansas Department of Higher Education. Current requirements are found in Appendix D.

Non-Traditional Courses: With prior approval, of the principal, students may enroll in correspondence courses, summer school, and independent study courses for remediation or enrichment. Courses taken outside of the Fayetteville School District will only count toward graduation when approved by the principal.

Participation in Commencement Ceremonies: Students who have fulfilled all requirements for graduation as established by the Fayetteville Board of Education Policy Number 5127 (see Appendix B) may participate in commencement ceremonies. **Students who are within one unit of completing graduation requirements may participate in commencement ceremonies, but will not receive a diploma until all requirements are met.**

Repeated Courses: Students may re-enroll in any course when they desire to improve understanding or raise their grade point average. Upon successful completion of the repeated course of the same title, the higher grade will be retained on the transcript, and the lower grade will be removed.

Schedule Changes: Students will have a limited opportunity to make adjustments in their schedules at the beginning of each semester. Students and parents need to be aware that the choices made on the pre-registration form and at CAP conferences are binding because scheduling is based on these pre-registration choices. Schedule changes will be permitted for the following reasons:

- when a student completes a course during summer school and no longer needs a course previously requested
- when a student fails a course prerequisite
- when a change is required due to a clerical error, to balance class loads, or to meet graduation requirements
- when a teacher recommends a change in the level of a course, in writing
- when enrollment in a course is insufficient for the course to be offered or when faculty is not available to teach a course.

Note: Students must remain in the classes assigned until the schedule request has been processed and a decision is made. Students dropping a class after two weeks into a semester will receive a WF; after nine weeks, it is a "F". Exceptions to this require the principal's approval. Dual attendance at district high schools is encouraged. Both East and West campuses provide challenging courses in particular areas of study. However, students who choose to attend both schools must make an informed choice and not expect to transfer back and forth. Student transfers are allowed at the nine weeks grading periods only.

Summer School: Fayetteville School District's summer school program information may be found in Appendix C.

Vital Link: The Vital Link program is designed to introduce all eighth grade students to the academic and vocational skills necessary for the work place.

Website Address for Fayetteville School District: www.fayar.net

FAYETTEVILLE HIGH SCHOOL

School Profile 2003-2004

1001 Stone Street
Fayetteville, AR 72701
479-444-3050 (Office)
479-444-3056 (Fax)

School and Community Data

Fayetteville High school is a public four-year school where the freshman year is completed at two local junior high schools. The student enrollment for the 10th, 11th, and 12th grades is approximately 1,580. The senior class ranges in size from 450-500. The CEEB-ACT code is 040-770. FHS is accredited by the North Central Association of Secondary Schools. The school year is comprised of two 18-week semesters.

Fayetteville is located in extreme Northwest Arkansas, has a population of 59,000, and is home of the main campus of the University of Arkansas. The University fosters a largely professional community, which is reflected in the curriculum of Fayetteville High School.

School Staff

The principal of Fayetteville High School is Don French. The caseload for counseling is equally divided alphabetically by the student's last name among four counselors as follows:

| | | | |
|------|---------------------|-----------------------|-----------------------|
| A-D | Dr. Berta Seitz | Counseling Phone #: | 479-444-3050 ext. 106 |
| E-K | Mrs. Dawn Norman | Counseling Assistant: | Jeannie Cabello-Penn |
| L-Rd | Mrs. Leslie Zeagler | Registrar: | Leanne Price ext. 107 |
| Re-Z | Ms. Debbie Goodell | | |

Marking System and Related Procedures

Fayetteville High School uses a 4.0 grading scale for all courses except Advanced Placement courses. The passing grade in any course is "D". The least amount of credit awarded is 0.50 unit for one semester's work. The grading scale and grade points are awarded as follows:

| Current Grading Scale | Regular, Honors, & College Placement | Advanced Placement Course |
|-----------------------|--------------------------------------|---------------------------|
| A 90-100% | A 4.0 pts. | A 5.0 pts. |
| B 80- 89% | B 3.0 pts. | B 4.0 pts. |
| C 70- 79% | C 2.0 pts. | C 3.0 pts. |
| D 60- 69% | D 1.0 pts. | D 2.0 pts. |
| F 0- 59% | F 0.0 pts. | F 0.0 pts. |

All courses are included in computing in GPA and class rank. These are the exceptions: (1) Classes graded with W/P indicating withdraw/passing (2) "P" which designates a passing grade (3) Classes graded with W/F indicating withdraw/failing (4) The maximum of one unit of Physical Education is used. GPA and class rank are calculated at the end of the junior year and again at the end of the first and second semesters of the senior year. Rank-In-Class is reported as follows:

- Students with above a 4.0 will be ranked #1.
- Students with 4.0 will be ranked #2.
- Students with below 4.0 will be ranked #3 downward based on their GPA.

EAST CAMPUS COURSE LIST

NOTE: Students wishing to take courses at both East Campus and West Campus should plan a schedule which would allow them to spend half of their day at each campus. With the schedules at each school being different, moving from one campus to the other for one or two hours is not practical from a scheduling point of view. (Exception: Drafting and Medical Professions may allow for one-hour classes.)

| | | |
|---|---------------|--|
| AGRICULTURE | Page 5 | |
| 844033 Agriculture Science and Technology | YR | |
| 844133 Animal Science | F | |
| 844232 Advanced Animal Science - Special Topics | S | |
| 844333 Food Science | F | |
| 844433 Biological Sciences in Agriculture | S | |
| 844533 Environmental Resources | F | |
| 844633 Management of Natural Resources | S | |
| 844733 Introduction - Horticultural Science | F | |
| 840833 Plant Science | S | |
| 845033 Introduction – Agri Mechanics | YR | |
| 845133 Agriculture Power Systems | YR | |
| 845233 Agriculture Metals – Arc/Tig/Mig Welding | YR | |
| 845333 Agricultural Structural Systems | YR | |
| 844933 Agri Business Management & Marketing | F/S | |
| Agriculture Technology Apprenticeship | YR | |

| | | |
|-----------------------------|---------------|--|
| ART | Page 8 | |
| 631011 Art History | F/S | |
| 630433 Foundations in Art | F/S | |
| 630633 Studio II | YR | |
| 630713 Senior Studio | YR | |
| 630833 3-Dimensional Art | YR | |
| 630233 Studio Survey | F/S | |
| 630331 AP Studio Art | YR | |
| 630923 Advanced Visual Arts | YR | |

| | | |
|--|----------------|--|
| BUSINESS TECHNOLOGY | Page 10 | |
| 810133 Computerized Keyboarding | F/S | |
| 812033 Computerized Keyboarding Applications | F/S | |
| 810333 Word Processing I | F/S | |
| 810433 Word Processing II | F/S | |
| 812333 Computerized Business Applications | YR | |
| 810533 Desktop Publishing I | F/S | |
| 811213 Desktop Publishing II | F/S | |
| 810633 Spreadsheet/Database | YR | |
| 812233 Office Management | YR | |
| 812733 Management | YR | |
| 810813 Multimedia I | F/S | |
| 812133 Multimedia II | F/S | |
| 810933 Programming I | F/S | |
| 811033 Programming II | F/S | |
| 811633 Money & Banking | YR | |
| 811433 Computerized Accounting I | YR | |

| | |
|---------------------------------------|-----|
| 811513 Computerized Accounting II | YR |
| 810723 Enterprise Management | F/S |
| 812433 Banking Public Relations | F/S |
| 811733 Business and Finance Law | F/S |
| 811833 Banking and Finance Operations | S |

| | | |
|--|----------------|--|
| COMPUTER SCIENCE | Page 13 | |
| 002133 Introduction to Programming in JAVA | YR | |
| 002231 AP Computer Science A in JAVA | YR | |
| 002331 AP Computer Science AB in JAVA | YR | |
| 818265 Unix/Linux Server and Workstation | YR | |

| | | |
|--------------------------|----------------|--|
| DRAMA | Page 15 | |
| 641033 Drama I | F/S | |
| 641133 Drama II | YR | |
| 641233 Drama III | YR | |
| 641533 Drama IV | YR | |
| 641313 Technical Theatre | YR | |
| Drama Apprenticeship | YR | |

| | | |
|--|----------------|--|
| ENGLISH | Page 16 | |
| 110103 Sophomore English | YR | |
| 113102 Honors American Studies | YR | |
| 113003 American Lit/American History | YR | |
| 110513 Junior English | YR | |
| 110813 Junior English/Creative Writing | YR | |
| 113623 Senior English: Modern Short Stories from Around the World | YR | |
| 113723 Senior English: World Mythology | YR | |
| 113823 Senior English: Reader's Choice | YR | |
| 110611 AP Language/Composition | YR | |
| 110711 AP Literature | YR | |
| 001133 Literary Magazine (elective credit) | YR | |

| | | |
|---|----------------|--|
| ESL - COURSES FOR LIMITED ENGLISH SPEAKERS | Page 19 | |
| 115035 English as a Second Language I | YR | |
| 115135 English as a Second Language II | YR | |
| 115235 English as a Second Language III | YR | |

FAMILY AND CONSUMER SCIENCES Page 20

| | | |
|--------|---------------------------|-----|
| 823433 | Family Dynamics | YR |
| 823033 | Food and Nutrition | F/S |
| 823333 | Parenting | F/S |
| 823633 | Money Management | F/S |
| 823233 | Nutrition for Life | F/S |
| 823133 | Housing & Interior Design | F/S |

FAYETTEVILLE ADVANCED SPATIAL & SERVICE TECHNOLOGY CENTER Page 21

| | | |
|--------|-----------|----|
| 001733 | FASST I | YR |
| 001833 | FASST II | YR |
| 001933 | FASST III | YR |

FAYETTEVILLE CAREER ACADEMY Page 22**FINE ARTS - SEE ART, DRAMA, MUSIC, JOURNALISM (photography)****FOREIGN LANGUAGE Page 23**

| | | |
|--------|------------------------------|----|
| 720133 | Narrative French | YR |
| 720233 | French I | YR |
| 720333 | French II | YR |
| 720433 | French III | YR |
| 720631 | AP French IV | YR |
| 730733 | Narrative German | YR |
| 730833 | German I | YR |
| 730933 | German II | YR |
| 731033 | German III | YR |
| 731231 | AP German IV | YR |
| 711433 | Spanish for Spanish Speakers | YR |
| 711533 | Narrative Spanish | YR |
| 711633 | Spanish I | YR |
| 711733 | Spanish II | YR |
| 711833 | Spanish III | YR |
| 711933 | Spanish IV | YR |
| 712031 | AP Spanish Language IV | YR |
| 712131 | AP Spanish Literature V | YR |

HEALTH EDUCATION Page 26

| | | |
|--------|--|-----|
| 520133 | Health I | F/S |
| 523033 | Comprehensive Health | YR |
| 520233 | Health and Fitness Awareness | YR |
| 520413 | Sports Medicine | YR |
| 494129 | Intro Medical Professions Education I | F |
| 494132 | Intro Medical Professions Education II – Medical Terminology | S |
| 494128 | Medical Procedures | YR |
| 494125 | Human Anatomy/Physiology for Med Prof | YR |

HUMANITIES Page 28

| | | |
|--------|---|----|
| 001433 | Greek/Roman Classics (elective credit only) | YR |
| 111823 | Asian Studies (elective credit only) | YR |
| 421623 | Cultural Studies | YR |

JOURNALISM Page 29

| | | |
|--------|----------------|-----|
| 651433 | Photography I | F/S |
| 651533 | Photography II | YR |
| 130233 | Journalism I | F |
| 130433 | Newspaper | YR |
| 130133 | Yearbook | YR |

MARKETING Page 30

| | | |
|--------|------------------------------------|-----|
| 888133 | Retailing | F |
| 888033 | Advertising | S |
| 888213 | Marketing | YR |
| 888523 | Marketing Management | YR |
| 492044 | Salesmanship | F |
| 492019 | Fashion Merchandising | S |
| | Marketing/Retailing Apprenticeship | F/S |

MATHEMATICS Page 31

| | | |
|--------|------------------------------------|-----|
| 230333 | Algebra I | YR |
| 240433 | Applied Geometry | YR |
| 240533 | Geometry | YR |
| 231033 | Algebraic Connections | YR |
| 230833 | Algebra II | YR |
| 230932 | Honors Algebra II | YR |
| 253032 | College Prep Algebra With Trig | YR |
| 253132 | Trigonometry/Introductory Analysis | YR |
| 251732 | Pre-calculus | YR |
| 253331 | AP Statistics | YR |
| 251931 | AP Calculus AB | YR |
| 252031 | AP Calculus BC | YR |
| 251830 | College Algebra Concurrent | F/S |
| 252130 | Finite Math Concurrent | S |

MUSIC Page 34

| | | |
|--------|-----------------------|----|
| 610133 | Band | YR |
| 610233 | Music Theory | YR |
| 620333 | Concert Choir | YR |
| 620503 | Select Men's Chorus | YR |
| 620103 | Select Women's Chorus | YR |
| 620233 | A Capella Choir | YR |

ORAL COMMUNICATION/DEBATE/FORENSICS**Page 35**

| | | |
|--------|--------------------------------------|-----|
| 120133 | Oral Communications: Practical Com. | F/S |
| 120233 | Oral Communications: Public Speaking | F/S |
| 120333 | Argumentation and Debate | YR |
| 120433 | Forensics I | YR |
| 000010 | Forensics II | YR |
| 000011 | Forensics III | YR |
| 000012 | Debate I | YR |
| 000013 | Debate II | YR |

PHYSICAL EDUCATION**Page 37**

| | | |
|--------|--------------------------------|-----|
| 510833 | Weight Training | F/S |
| 510933 | Personal Fitness | F/S |
| 511033 | Recreational Sports Activities | F/S |
| 511133 | Team Sports A | F/S |
| | Team Sports B - Athletics | F/S |
| 511333 | Athletic Football | |
| 511433 | Men's Basketball | |
| 511533 | Women's Volleyball | |
| 511633 | Women's Basketball | |
| 511733 | Women's Soccer | |
| 511734 | Men's Soccer | |
| 511833 | Men's Baseball | |
| 511933 | Women's Softball | |
| 531033 | Cheer/Pom | |

SCIENCE**Page 38**

| | | |
|--------|--------------------------|----|
| 320133 | Earth Science | YR |
| 310103 | Biology I | YR |
| 310203 | Biology II | YR |
| 310302 | Accelerated Biology | YR |
| 310402 | Field Biology | YR |
| 310521 | AP Biology | YR |
| 310813 | Human Anatomy/Physiology | YR |
| 320933 | Chemistry | YR |
| 321032 | Accelerated Chemistry | YR |
| 321111 | AP Chemistry | YR |
| 321433 | Physics A | YR |
| 321531 | AP Physics B | YR |
| 321611 | AP Physics C | YR |

SOCIAL STUDIES**Page 41**

| | | |
|--------|--|-----|
| 430103 | American History 1870-Present | YR |
| 113102 | Honors American Studies Block | YR |
| 113003 | American Lit/American History Block | YR |
| 450813 | Geography | F/S |
| 461213 | Sociology | YR |
| 461113 | General Psychology | YR |
| 461411 | AP Psychology | YR |
| 411513 | American Government | F/S |
| 411311 | AP Government and Politics | YR |
| 420713 | World History: Ancient & Medieval Civilization | YR |
| 420913 | World History: Modern Civilization | YR |
| 420511 | World History: AP European History | YR |
| 421623 | Cultural Studies | YR |
| 421710 | Western Civilization I - WCIV 1003 | F |
| 421810 | Western Civilization II - WCIV 1013 | S |
| 460133 | Street Law | F/S |

MISCELLANEOUS ELECTIVES**Page 44**

| | | |
|--------|-------------------------------------|----|
| 000733 | Student Council | YR |
| 818255 | Computer Repair-Diagnostics | YR |
| 818245 | Computer Repair-Computer Operations | YR |
| 818235 | Computer Repair-Computer Networking | YR |
| 921136 | Transitions | YR |
| 000833 | Jr. Air Force ROTC | YR |
| 921136 | Transition | YR |
| 818235 | Computer Networking I | YR |
| 818335 | Computer Networking II | YR |

NON-CREDIT CLASSES**Page 45**

| | | |
|--------|---------------------------|-----|
| 000933 | Study Hall | F/S |
| 000943 | Study Hall for Bus Riders | F/S |

SPECIAL EDUCATION SERVICES**Page 45****NON-TRADITIONAL ACADEMIC SERVICES****Page 45**

Academy
School Within A School

EAST CAMPUS COURSE DESCRIPTIONS

AGRICULTURE

INTRODUCTORY COURSE:

844033 Agri Science & Technology (10, 11, 12)
1 Year, 1 Unit

This course encompasses the applied and technical study of the various segments of the agriculture industry. Basic animal, plant, and soil sciences, and agriculture mechanics skills are introduced. The course also covers the history and current status of Future Farmers of America (FFA) and agriculture careers. Students will be required to keep a notebook, master a wide range of skills, and participate in all class activities.

ANIMAL & BIOLOGICAL SCIENCE COURSES:

844133 Animal Science (10, 11, 12)
1 Semester, ½ Unit
Fall only

This course is an introduction to the sciences involved in animal production. Animal nutrition, physiology, feeds and feeding, health genetics, breeding, reproduction, care, management, and marketing are emphasized. Students will be required to keep a notebook, participate in labs, and master a wide variety of skills.

FFA is a community minded club that boosts a membership of 70 members.

FFA adopts families during December in conjunction with the Salvation Army or local elementary schools.

844232 Advanced Animal Science: Special Topics (10, 11, 12)
1 Semester, ½ Unit
Spring only

This course covers advanced concepts involved with the production, management, and science of animals. It emphasizes a specific animal species, such as equine science, beef science, or poultry science. The course reviews the basic animal science concepts, but goes much further into specific animal topics. Students will be required to keep a notebook, master a wide range of skills, and participate in all class activities.

844333 Food Science (10, 11, 12)
1 Semester, ½ Unit
½ Unit FHS Life Science Credit
Fall only

Basic principles of the food industry and the sciences associated with production, processing, storage, preparation, distribution, food safety, nutrition, nutritional requirements for human health, and the process used to insure an adequate and wholesome food supply are covered in this course. Students will be required to keep a notebook, master a wide range of skills, and participate in all class activities.

844433 Biological Sciences in Agriculture (10, 11, 12)
1 Semester, ½ Unit
½ Unit FHS Life Science Credit
Spring only

The biological sciences in agriculture continue to grow and expand at a tremendous rate. This course introduces the student to a variety of the sciences which are used daily in agriculture. Animal and plant sciences are covered, as well as new fields of biotechnology. Students will be required to keep a notebook, conduct experiments, and master a wide range of skills.

ENVIRONMENTAL SCIENCE COURSES:

844533 Environmental Resources (10, 11, 12)
1 Semester, ½ Unit
Fall only

This course covers the principles of fish and wildlife management through the technical study of birds, mammals, fishes, and plant life. Included are related careers in game habitat and management and the study of the recreational possibilities of our main natural resource: private, state, and national recreation areas. Students will be required to keep a notebook, master a wide range of skills, and participate in all class activities.

844633 Management of Natural Resources (10, 11, 12)
1 Semester, ½ Unit
Spring only

Covered in this course are the principles of natural resources through the technical and scientific study of soil formation, erosion reclamation, conservation, water use, wildlife, outdoor recreation, land use, and the careers associated with this field. Students will be required to keep a notebook, master a wide range of skills, and participate in all class activities.

PLANT SCIENCE COURSES:

844733 Intro-Horticultural Science (10, 11, 12)
1 Semester, ½ Unit
Fall only

Principles of horticulture and horticultural crops including the biology, chemistry, and physics of plant classification, structure, physiology, environmental factors, and climate are studied. The greenhouse is used for experiments and caring for plants. Students will be required to keep a notebook, master a wide range of skills, and participate in all class activities.

840833 Plant Science (10, 11, 12)
1 Semester, ½ Unit
Spring only

This course covers the principles of producing agricultural crops, fruits, and vegetables for human and animal consumption. All aspects of planting, maintaining, harvesting, and marketing are stressed. The care, maintenance, and operation of a greenhouse and greenhouse crops are included. Students will be required to keep a notebook, master a wide range of skills, and participate in all class activities.

AGRICULTURE MECHANICS COURSES:

845033 Intro-Agriculture Mechanics (10, 11, 12)
1 Year, 1 Unit

This course covers the application and technical study of basic mechanical skills for students interested in mechanical applications found throughout agriculture. Competency-based instruction on basic mechanical skills and application is introduced. Students will be required to keep a notebook, master a wide range of skills, and participate in all class activities.

845133 Agriculture Power Systems (10, 11, 12)
1 Year, 1 Unit

This course is designed as an advanced agriculture mechanics course which quickly reviews concepts learned in basic mechanics classes, then moves on to more complex concepts and skills. Topics to be covered include types of power, agriculture power sources used in industry, and the applied physics of power. Students will be required to keep a notebook, master a wide range of skills, and participate in all class activities.

845233 Agriculture Metals-Arc/Tig/Mig Welding (10, 11, 12)
1 Year, 1 Unit

This course reviews the concepts in Agriculture Power Systems and emphasizes metalworking in agriculture and industry. Repair, maintenance, and design of machinery are covered in this course. Students will be required to keep a notebook, master a wide range of skills, and participate in all class activities.

845333 Agriculture Structural Systems (10, 11, 12)
1 Year, 1 Unit

This course reviews and reinforces basic principles introduced in agriculture mechanics courses while introducing students to new areas in agriculture mechanics which are dictated by area industry for incoming industrial maintenance technicians. The class works closely with students in Agriculture Apprenticeship to prepare them for workplace readiness. Competency-based instruction in fourteen areas of technical study is used as the basis for classroom and practical shop activities. Students will be required to keep a notebook, master a wide range of skills, and participate in all class activities.

AGRICULTURE BUSINESS CLASSES:

**844933 Agriculture Business Management and Marketing (10, 11, 12)
1 Semester, ½ Unit
Fall or Spring**

This course addresses the business-related applications of agriculture: supply and demand, marketing, retailing, distribution, consumer relations, government organization systems and finance. Various types of businesses and management practices will be studied with the focus on “producer to consumer processes”. Students will be required to keep a notebook, master a wide range of skills, and participate in all class activities.

Agriculture Technology Apprenticeship (11, 12)

1 Year (variable credit - see below)

Prerequisite: Approval of Mr. Laney

Students must be accepted into Apprenticeship before registering for the course.

The Agriculture Technology Apprenticeship is designed to develop skills for future employment in agriculture technology. Students earn ½ unit of credit (180 hours per semester, 10 hours per week), 1 unit of credit (270 hours per semester, 15 hours per week), or 1½ units of credit (360 hours per semester, 20 hours per week) for Agriculture Technology Apprenticeship depending on the number of hours worked. Contact Mr. Laney at 444-3050, extension 129 for additional information about this new opportunity. (Some employers require drug testing as a condition of employment.)

The agriculture program, FFA, has successfully competed against schools statewide. The following honors have been received:

- Over the past three years the agri mechanics team competed against 17 schools and captured either first or second place at the district level.
- At the state level the agri mechanics team traditionally places in the top 15. A sixth place finish in 2000 resulted in a gold emblem award.
- The electricity team received fourth place in the district sub-area.

The agriculture department is one of the largest areas within Fayetteville Youth Apprenticeship Program with 19 students currently participating. Due to the strong academics taught in the agriculture program apprenticeship and FFA many students have been quite successful over the past years.

Agriculture instructor, Mr. Bill Laney, was a presenter at the Arkansas Educational Development Council on developing and implementing the youth apprenticeship programs in the school system. He is also a member of the UA College of Agriculture Alumni Board who’s primary focus is the development of scholarships for high school students across the state.

While at FHS, Agriculture instructor, Mr. Jim Frisby, was named “Agri Science Teacher of the Year” for the state of Arkansas by the National FFA Foundation.

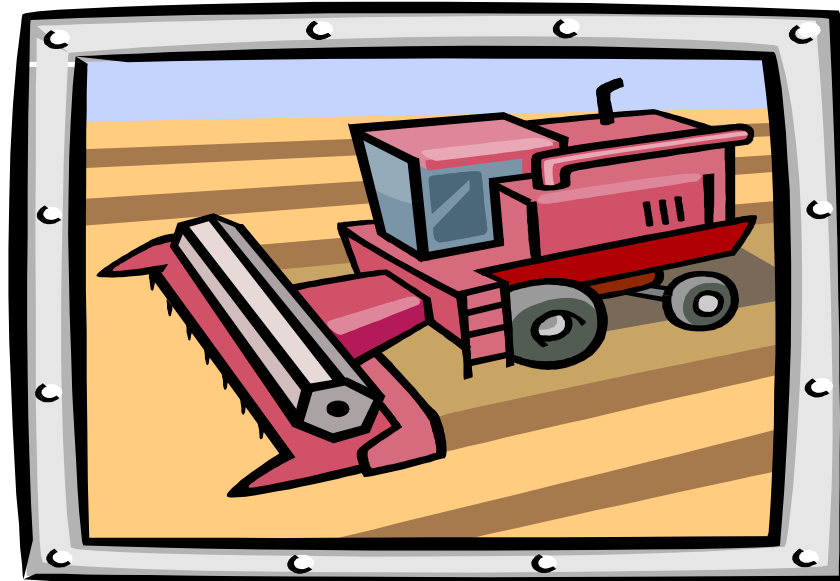

ART

631011 Art History (10, 11, 12)
1 Semester, ½ Unit
Fall or Spring

Art History is designed to offer students an opportunity to gain an understanding of and appreciation for architecture, sculpture, painting, and other art forms in the context of history and culture. Students will learn to recognize notable works of art and will be able to examine all art forms critically, analyzing intellectually and with appreciation what they see. This class fulfills the ½ unit fine arts credit for graduation.

630433 Foundations in Art (10, 11, 12)
1 Semester, ½ Unit
Fall or Spring
Prerequisite: No previous art required

Foundations in Art fulfills the ½ unit fine arts credit for graduation. Students will work on two-dimensional assignments selected from pencil, pastel, water color and ink. Students are expected to complete all assignments, make good use of time and care for supplies and equipment. Grades are primarily based on effort, following instructions, and individual improvement. Selected pieces of art work may be saved for contests and exhibits. There is a \$5 art supply fee.

Thirteen drawings are selected each year from the students in Studio I to illustrate the community calendar produced by the Jr. Civic League.

All of the murals at Fayetteville High School have been painted by the students in the Studio II and Senior Studio art classes.

Most of the art accepted for publication in the Connotations literary magazine is produced by students in the art department.

Students in the 3D Art Studio class spend much of the fall semester creating giant masks and puppets for the First Night Parade to help our community bring in the New Year.

Please note the following:

All students wishing to enroll in Studio II, 3-D Studio, Senior Studio, AP Studio, or Independent Studio must have approval of Mr. Remmers. To arrange for an appointment students must contact Mr. Remmers at 444-3050 (or [www. jremmers@fayar.net](mailto:jremmers@fayar.net)). This must occur at least one week prior to the East Campus CAP conferences.

630633 Studio II (10, 11, 12)
1 Year, 1 Unit

Prerequisite: An “A” in Studio I or ninth grade art and teacher approval. Students new to FHS will be required to submit a sketchbook and portfolio for evaluation and approval. **There is a summer assignment.**

Projects are designed to give the more successful students a wider range of media experiences in two-dimensional work. This is an Honor’s Level, pre-AP curriculum. Students will be expected to put in a substantial quantity of time outside of the scheduled class time. There will also be some emphasis on preparing projects for display. Selected pieces of art work may be saved for contests and exhibits. There is a \$20 art supply fee.

630713 Senior Studio (11, 12)
1 Year, 1 Unit

Prerequisite: Studio II and/or a portfolio must be submitted and approved by the FHS teacher. It is recommended that students enrolling in Senior Studio to have already taken Art History or be enrolled concurrently.
There is a summer assignment.

This is a course for juniors and seniors who have successfully completed Studio II and/or submitted an approved portfolio. This Honor’s Level curriculum is designed for the serious self-motivated student who has the desire to explore one or more media in depth. The fall semester will include specific two-dimensional assignments. The spring semester will include figure drawing, a public art unit, and individual assignments. During both semesters students will be expected to write formal reviews of local art exhibits as well as art history papers. There is a \$25 supply fee and students will also be expected to supply additional materials.

630833 3 Dimensional Art (10, 11, 12)

1 Year, 1 Unit

Prerequisite: Approval by instructor and an “A” in Studio I or ninth grade art. Students new to FHS will be required to submit a portfolio, sketchbook, or examples of previous three-dimensional work for evaluation and approval, and a note from a previous art teacher verifying a strong work ethic and a cooperative attitude.

This course includes sculpture in wood, paper mache, and an emphasis on clay construction. Students will be expected to purchase their own materials and tools and not be afraid to get dirty.

630233 Studio Survey (11, 12)

1 Semester, ½ Unit

Fall or Spring

Prerequisite: Studio I, grade B or above

Students will work on two-dimensional and three-dimensional artworks that reflect a variety of styles. Drawing, painting, collage, and a variety of three-dimensional materials will be used. Students are expected to complete all assignments, make good use of time, and care for supplies and equipment. Grades are based on effort, following instructions, and individual improvement. There is a \$5 art supply fee.

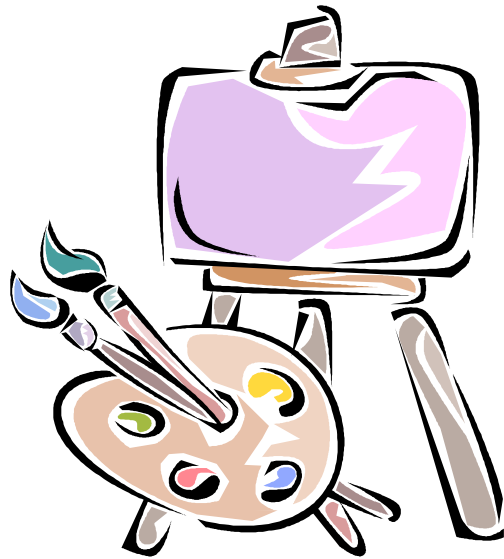

630331 AP Studio Art (11, 12)

1 Year, 1 Unit

Prerequisite: Successful completion of Studio II or 3-D Studio and/or have presented an approved portfolio.

It is recommended that students enrolled in AP Studio Art also be enrolled in either Senior Studio or 3-D Studio in order to have the opportunity to produce the quantity of work required for an AP portfolio (23-30 pieces of work). This course demands substantial dedication and students must put in significant time outside of class to complete the requirements. There is a \$25 art fee and a summer assignment.

630923 Advanced Visual Arts (12)

1 Year, 1 Unit

Prerequisite: Previous enrollment in FHS art classes and teacher approval of a portfolio.

This course is designed for seniors who have exhibited exemplary talent and a sound work ethic who wish to focus on a specific area of advanced study.



BUSINESS TECHNOLOGY

Computer Course Sequence

Students must successfully complete at least one course in each level before moving to the next higher level. Students must also have completed the prerequisites for each course.

| | |
|-------------|---|
| Level One | Computerized Keyboarding Computer Technology: Introduction* |
| Level Two | Computerized Keyboarding Applications Computer Business Applications Word Processing I |
| Level Three | Word Processing II Desktop Publishing I Spreadsheet/Database Multimedia I Programming I |
| Level Four | Office Management Desktop Publishing II Multimedia II Programming II |

* Beginning in the 2003-2004 school year, Computer Technology: Introduction will only be taught at the junior high level.

810133 Computerized Keyboarding (10, 11, 12)
1 Semester, ½ Unit
Fall or Spring
Level 1

Computerized Keyboarding is a beginning level course designed to teach the basic keyboarding skills. Students will develop accuracy by learning the touch operation of alphanumeric/keyboard characters. IBM compatible computers and specialized software will be utilized to build a firm foundation in the keyboarding skills crucial for success in today's technological society. This class is not recommended for students who have already successfully completed a keyboarding class.

812033 Computerized Keyboarding Applications (10, 11, 12)
1 Semester, ½ Unit
Fall or Spring
Prerequisite: Computerized Keyboarding
Level 2

Computerized Keyboarding Applications is a one-semester course designed to further develop keyboarding skills. Emphasis is placed on the following: speed and accuracy; proofreading; producing mailable copy from rough draft; and the composition of various types of business communications.

810333 Word Processing I (10, 11, 12)
1 Semester, ½ Unit
Fall or Spring
Prerequisite: Computerized Keyboarding
Level 2

This one-semester course is designed to provide students with fundamental word processing skills necessary to produce simple documents. Topics include creating and editing documents, proofreading, text alignments and enhancements, formatting documents, and multiple-page documents. Microsoft Word will be used for this course.

810433 Word Processing II (10, 11, 12)
1 Semester, ½ Unit
Fall or Spring
Prerequisites: Computerized Keyboarding and Word Processing I
Level 3

Word Processing II is a one-semester course designed to provide students with advanced word processing skills. Topics include multiple documents, macros, columns and tables, calculate and sort, merge, and the creation of simple desktop publishing documents. Microsoft Word will be used for this course.

812333 Computerized Business Applications (10, 11, 12)
1 Year, 1 Unit
Prerequisites: Computerized Keyboarding and Word Processing I
Level 2

Computerized Business Applications is a two-semester course designed to prepare students with an introduction to business applications that are necessary to live and work in a technological society. Emphasis is given to hardware, concepts, and business uses of applications. The business applications covered are word processing, graphics, spreadsheet, database, and electronic mail.

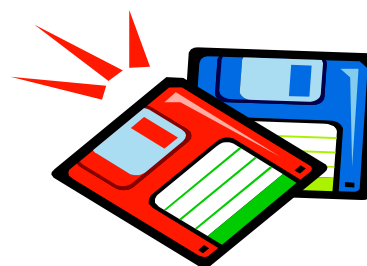

810533 Desktop Publishing I (10, 11, 12)**1 Semester, ½ Unit****Fall or Spring****Prerequisites:** Word Processing I or Computerized Business Applications**Level Three**

Desktop Publishing I is a one-semester course that will provide students with the skills to create flyers, certificates, programs, newsletters, and brochures. The principles of good design and how to use graphical and text features in a publication will be included in this course. Software with desktop publishing capabilities will be used.

811213 Desktop Publishing II (10, 11, 12)**1 Semester, ½ Unit****Fall or Spring****Prerequisite:** Desktop Publishing I**Level 4**

Desktop Publishing II is a one-semester course designed to study the process of analyzing information and audience, and choosing the appropriate visual signals to communicate the desired message effectively. Applied principles are used to analyze and organize information, set up a design structure, and produce special visual expressions. Desktop Publishing software will be used.

810633 Spreadsheet/Database (10, 11, 12)**1 Year, 1 Unit****Prerequisite:** Computerized Keyboarding and Computer Technology: Introduction or Computerized Business Applications or Word Processing I**Level 3**

This course teaches the management of numbers and information using a computer. First semester will be devoted to learning how to create, manage, and manipulate numbers using spreadsheets. The software used will be Microsoft Excel. Second semester will be devoted to learning how to create, manage, and manipulate information using databases. The software used will be Microsoft Access.

812233 Office Management (11, 12)**1 Year, 1 Unit****Prerequisites:** Computerized Keyboarding, Word Processing I and Word Processing II**Level 4**

Office Management is a two-semester course focusing on management and supervision of the office environment. The course covers technology, human relations, and communications.

812733 Management (11, 12)**1 Year, 1 Unit****Prerequisite:** Computer Technology: Introduction or Computerized Business Applications or Word Processing I

Management is a 1 year course that assists the student in understanding basic management functions. Students study the management process, decision-making, environmental factors, basic ethics, and social responsibility. Planning, organizing, leading, and controlling are emphasized as well as basic concepts of staffing, leadership, communications, entrepreneurship, and international management.

810813 Multimedia I (10, 11, 12)**1 Semester, ½ Unit****Fall or Spring****Prerequisite:** Word Processing I or Computerized Business Applications**Level 3**

This course teaches students to use a computer to combine pictures, video, and audio with various software programs to communicate information. The students will create animations, presentations, videos, and webpages. Some of the software used in the classroom will be Microsoft PowerPoint, Lumiere Video Studio, Microsoft FrontPage 2000, and CU-SeeMe Video Conferencing Software. The class provides hands-on experience with Digital Cameras, Video Camcorders, Video Conferencing Cameras, Scanners, Video Capture Devices, and CD-ROM Writing.

812133 Multimedia II (11, 12)**1 Semester, ½ Unit****Fall or Spring****Prerequisite:** A or B in Multimedia I and teacher approval**Level 4**

This course is designed for students who would like to further explore the knowledge acquired in the first part of the course to combine pictures, video, and audio with various software programs to communicate information. Some of the software used in the classroom will be Microsoft PowerPoint, Lumiere Video Studio, Microsoft FrontPage 2000, and CU-SeeMe Video Conferencing Software, and Ulead Gif Animator. The class provides hands-on experience with Digital Cameras, Video Camcorders, Video Conferencing Cameras, Scanners, Video Capture Devices, and CD-ROM Writing.

810933 Programming I (10, 11, 12)

1 Semester, ½ Unit

Fall or Spring

Prerequisite: Computerized Keyboarding and Computer Technology: Introduction or Computerized Business Applications or Word Processing I

Level 3

This course will provide an introduction to computer programming utilizing the Visual Basic computer language and will explore skills and techniques necessary for using the computer to solve problems. Skills will be developed through hands-on experience with microcomputers. A strong background in math is needed for this course. A \$10 workbook fee is required.



811033 Programming II (10, 11, 12)

1 Semester, ½ Unit

Fall or Spring

Prerequisite: Programming I
Level 4

Programming II is a one-semester course that is a continuation of the study of the language taught in Programming I. Skills will be developed through hands-on experience with microcomputers. A strong math background is needed for this course. An introduction to the use of the C++ language will be provided during the second quarter of this class. A \$10 workbook fee is required.

811633 Money & Banking (11, 12)

1 Year, 1 Unit

Prerequisite: Computer Technology: Introduction or Computerized Business Applications or Word Processing I

This course is a partnership with ARVEST Bank, Fayetteville. It is designed to introduce and stimulate the student's interest in money and banking and how it affects their lives. Students will learn about the stock market and manage their own computerized stock portfolio in a classroom competition. On one day, they will job shadow an Arvest Bank Employee. Discussion in the classroom will include the Federal Reserve System, Wall Street, marketing & sales, business law, checking accounts, savings accounts, and credit & interest. Guest speakers from ARVEST bank, Fayetteville are scheduled each Wednesday to share their knowledge and experience. Some of the planned field trips include a tour of ARVEST Bank, Fayetteville on the square and the ARVEST Check Processing Center in Lowell. Opportunities for community service will be available. Students in the class are honored for their participation by receiving a membership on ARVEST Bank, Fayetteville's Junior Bank Board.

811433 Computerized Accounting I (10, 11, 12)

1 Year, 1 Unit

Prerequisites: Computerized Keyboarding and Computer Technology: Introduction or Computerized Business Applications or Word Processing I

This first-year accounting course will provide a thorough background in the basic accounting procedures used to operate a business. It will also serve as a sound background for employment in office jobs and preparation for studying business courses in college. The Southwestern Computerized Accounting program will supplement text and workbook assignments, as well as simulated instructional packets. Quickbooks Pro 6.0 software will be utilized during the spring semester for a business simulation project. A \$10 workbook fee is required.

811513 Computerized Accounting II (11, 12)

1 Year, 1 Unit

Prerequisite: Accounting I

Students who were successful in completing the first year accounting course and who have a definite interest in a career in business should take this course in preparation for more advanced courses on the college level. Course content deals with partnerships and departmental, corporate, and cost accounting systems. QuickBooks Pro 6.0 software and calculators are integrated into daily assignments. A \$10 workbook fee is required.

810723 Enterprise Management (11, 12)
1 Semester, ½ Unit
Fall or Spring
Prerequisites: Computerized Keyboarding and Computer Technology: Introduction or Computerized Business Applications or Word Processing I

Enterprise Management is a one-semester course designed to offer an overview of the American business enterprise system. The course content focuses on planning, marketing, financing, and managing a small business.

812433 Banking Public Relations (11, 12)
1 Semester, ½ Unit
Fall or Spring
Prerequisite: Money and Banking

Banking Public Relations teaches students about the role of public relations in banking. How do banks attract customers and keep them loyal? Banks face increasingly stiff competition in the financial services industry. Banking Public Relations explains how banks understand consumer behavior, perform market research, select target markets, and develop strategies for selling to their target markets. Field Trips and Guest Speakers will be a part of this course. This course is done in partnership with McIlroy Bank & Trust.

811733 Business & Finance Law (11, 12)
1 Semester, ½ Unit
Fall or Spring
Prerequisites: Keyboarding and Computer Technology: Introduction or Computerized Business Applications or Word Processing I

This course is designed to introduce students to business law and financial law and how it affects their lives. Students will study law and the judicial system, laws pertaining to minors, consumer law, business law, contract law, agency law, property law, and credit law. The course will include guest speakers. A \$10 workbook fee is required.

811833 Banking & Finance Operations (11, 12)
1 Semester, ½ Unit
Spring Only
Prerequisites: Money and Banking and Banking Public Relations

This course is designed to introduce students to skills needed in the day-to-day operations of businesses and our financial community. Students will learn to use a ten-key pad for calculators and computers. Students will also learn to use word processing and spreadsheet applications on personal computers.



COMPUTER SCIENCE

002133 Introduction to Programming in JAVA (10, 11, 12)
1 Year, 1 Unit
Prerequisite: Algebra II or concurrent enrollment in Algebra II

This course is one of the prerequisites for AP Computer Science A. It will provide instruction in computer programming and will give students skills and techniques for using the computer to solve problems and to conduct investigations for math and science problems. Topics will include JAVA commands, program design and execution, debugging, loops, functions, and prototypes. Skills will be developed through hands-on experience with microcomputers. Experience with C++ or similar language would help in this course.

002231 AP Computer Science A in JAVA (10, 11, 12)
1 Year, 1 Unit
Prerequisite: Programming I or instructor approval

The major emphasis of this course is to familiarize the student with current programming methodologies. Students will learn programming techniques used in individual programming as well as team-based approaches to programming. Students will begin the year learning in-depth programming methods and will end the year working to develop a team-based project. The end of year project will consist of a computer game with each student responsible for his or her own part of the program. Students will develop awareness for particular algorithms and data structures needed to complete various program assignments. Students will be taught to design and implement computer-based solutions to achieve a successful well-organized program.

AP Computer Science is a college level course. Students should possess sufficient writing skills to facilitate communication of their programming methodology. This course is recommended for students with a "C" or better in Algebra II. Students who take this course should plan to work on the computer at least 5 hours a week outside of class.

002331 AP Computer Science AB in JAVA (10, 11, 12)
1 Year, 1 Unit
Prerequisite: AP Computer Science A in C++ or instructor approval

AP Computer Science AB is a more formal and in-depth study of algorithms, data structures, and abstraction. For example, binary trees are studied in Computer Science AB but not in Computer Science A. The Association for Computing Machinery (ACM) and the Institute of Electrical and Electronic Engineers (IEEE) Computer Society have published standards for the content of a college-level program in computer science that include recommendations for topics to be covered in the first two years of college. Computer Science AB course is consistent with a CS2 course in those sample curricula.

The goals of APCSAB are comparable to those in the introductory sequence of courses for computer science majors offered in college and university computer science departments. It is not expected, however, that all students in APCSAB will major in computer science at the university level. APCSAB is intended to serve both as an introductory course for computer science majors and as a course for people who will major in other disciplines that required significant involvement with computing.

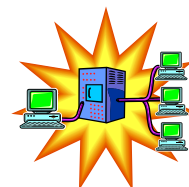

818265 Unix/Linux Server and Workstation Administration (10, 11, 12)
1 Year, 1 Unit

This course is designed for students who want to work on or maintain large-scale computer systems. The student will learn how to administer the operating system and install/configure a server designed for several users. Students enrolled in this program will learn advanced skills needed for successful administration. Students will learn basic commands and complete the year by installing the system and setting up all needed services. Students will have several projects to complete during the year and must keep current with the latest technology from various technical websites.

DRAMA

641033 Drama I (10, 11, 12)
1 Semester, 1/2 Unit
Fall or Spring
Fine Arts Credit

This course is to introduce students to the various elements of drama and for students to appreciate and understand drama while participating in a variety of activities. Selected theatre history, acting, improvisations, pantomimes, characterization, stage movement, script reading and analysis, and introduction to collaborative artist will be discussed

641133 Drama II (10, 11, 12)
1 Year, 1 Unit
Prerequisite: Drama I
Fine Arts or Humanities Credit

This is an introductory course to acting, technical theatre, and theatre history. Students will be expected to participate in all classroom drama activities. The method of presentation will be lectures, discussions, script reading, projects, line memorization, tests, and guest artists.



Four FHS drama students served as paid interns for the Boar's Head Players summer theatre program.

FHS drama students participate in shows produced by ARTS Live and the Arts Center of the Ozarks.

FHS Drama Department produced the shows *Murder on Nile*, *The Stinky Cheese Man*, and *The Sound of Music* during the 2002-2003 school year.



641233 Drama III (11, 12)
1 Year, 1 Unit
Prerequisite: Drama II and Audition or Instructor Approval
Fine Arts or Humanities Credit

This course is a play production and acting class. Areas of emphasis will be audition techniques, comic acting, acting Shakespeare, playwriting, one-act play production, and musical theatre (singing and dancing). Students are expected to work on school plays. Students will be evaluated on their rehearsal work, contribution to play productions, and class participation.

641533 Drama IV (12)
1 Year, 1 Unit
Prerequisite: Drama III or Instructor Approval
Fine Arts Credit

This course is a continuation of skills learned in Drama III. Areas of emphasis will be directing techniques, acting, 20th Century World Drama, a children's play production, and writing/acting workshop for elementary students.

641313 Technical Theatre (11, 12)
1 Year, 1 Unit
Prerequisite: Drama II or Instructor Approval
Fine Arts Credit

The course will be a study of the techniques associated with set design, set construction, lighting design, and costume design and construction. Students will be expected to work on all plays produced at the high school.

641433 Drama Apprenticeship (11, 12)

Drama Apprenticeship is designed to provide both classroom and on the job training for either the business aspects of theatre, the technical aspects of theatre, or a combination of the two. Students can earn ½ unit of credit (180 hours per semester; 10 hours per week), 1 unit of credit (270 hours per semester; 15 hours per week) or 1½ units of credit (360 hours per semester; 20 hours per week) for Drama Apprenticeship depending on the number of hours worked. Contact Mr. Rosenaur at 444-3050, ext. 128 for more information about this opportunity.

ENGLISH

Sophomores should choose from the following courses:

110103 Sophomore English

113102 Honors American Studies

113003 American Literature/American History

110103 Sophomore English (10) **1 Year, 1 Unit**

This course includes a study of literature written by United States authors from the perspective of our rich ethnic and cultural diversity. Emphasis is on both reading for scholastic success as well as reading for enjoyment. Students have an opportunity to review and practice effective writing skills beginning with good sentences and paragraphs as they move toward writing effective essays. Students will develop research skills through library-based projects. Critical thinking, organizational, and grammar/editing skills will be emphasized during the writing process. Students will learn critical reading skills that will challenge them as they read fiction, non-fiction, and poetry. All students will read and analyze The Crucible and a number of the following works: Black Like Me, House on Mango Street, A Separate Peace, The Great Gatsby, A Member of the Wedding. This survey of United States literature combined with composition skills prepares students for any of the course choices in the eleventh grade.

113003 American Literature/American History (10) **1 Year, 2 Units** (1 each of sophomore English and American History)

This two-semester course is designed for sophomores who will meet for a two-hour block to study American literature and history. Students will study the historical and literacy significance of events and analyze the voices of participants by conventional classroom methods of listening, speaking, presenting, note taking, questioning, and test performance skills. These activities will assure the student a position of active learning coupled with research based library projects and reading novels which instill an understanding of both literary and historical perspectives. Novel studies will include lessons from *Red Badge of Courage*, *The Jungle*, *All Quiet on the Western Front*, *The Great Gatsby*, *The Grapes of Wrath*, *The Sun Also Rises*, *A separate Peace*, and *Black Like Me*. Student projects will provide writing across the curriculum and the progression of learning according to Bloom's Taxonomy which includes levels of knowledge, comprehension, application, analysis, synthesis, and evaluation.

113102 Honors American Studies (10)

1 Year, 2 Units (1 each of AP U.S. History and sophomore English)

Prerequisite: A "B" or higher the first semester in Pre-AP English and Pre-AP History

SUMMER ASSIGNMENT IS DUE THE 1ST DAY OF CLASS.

Honors American English and AP United States History are offered within a two-period time block for the sophomore who desires an extensive interdisciplinary approach to American literature and history and who has exhibited a high level of interest, dedication, and aptitude for language arts and social studies. These courses provide an in-depth study of American literature and history, identifying major historical time periods, literary figures and their contributions. It is the intent of this block to provide the student with both the historical and literary perspectives of nineteenth and twentieth century America and to provide an experience of writing across the curriculum. Students will read and analyze *The Jungle*, *All Quiet on the Western Front*, *The Grapes of Wrath*, *The Great Gatsby*, *A Separate Peace*, *The Crucible*, and a modern novel of their choice. (See 110103 for other areas of study.) **Completion of a summer assignment is required for this course.** Weighted credit is given only for the AP U.S. History portion of this block class.

A nationally recognized critical thinking skills test will be used to identify students who have not taken the Pre-AP English and History. Students wishing to take this exam must contact Ms. Caver or Mr. Malony at 444-3050, ext. 100.

Fayetteville High School students are able to access university and county libraries from the school library.

Students in the Reader's Choice Senior English class tutor students from Jefferson Elementary in the spring.

Thirteen students scored 5 on the APLAC and nine scored 5 on the APLIT.

Juniors must choose from the following courses:

110513 Junior English

110813 Junior English/Creative Writing

110611 AP Language/Composition

110513 Junior English (11)

1 Year, 1 Unit

Students will read a variety of masterpieces representative of the English-speaking world that include *Lord of the Flies*, *Canterbury Tales*, and *Macbeth*. Students will experience a variety of writing experiences to develop critical thinking skills and improve their own writing process.

110813 Junior English/Creative Writing (11)

1 Year, 1 Unit

Students will read and discuss representative works of prose fiction, prose nonfiction, poetry, and drama from the English-speaking world. The primary goal of the course will be the production of student work. Each class member will focus attention upon one of the four genres listed above and prepare manuscripts for submission to the group. Considerable class time will be given to round-table discussion of individual work. Students will learn how to revise their work and how to edit the work of others.

110611 AP Language/Composition (11, 12)

1 Year, 1 Unit

Prerequisites: A 3.5 GPA or higher or written approval of spring semester English teacher attached to CAP registration, AP contract submitted by May 24

SUMMER ASSIGNMENT IS DUE THE 1st DAY OF CLASS.

AP Language and Composition is a yearlong course in writing for academic purposes. Students will develop their own writing processes and styles by completing a variety of essay assignments, including a five-week research paper during the spring semester. They will study the semantic, structural, and rhetorical resources of language as well as the history of English. Students can expect one hour of homework per night.

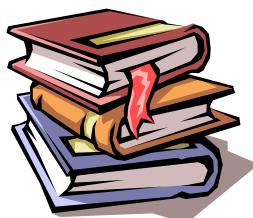

Seniors must select from the following courses:

113623 Senior English: Modern Short Stories from Around the World and Masterpieces of World Literature

113723 Senior English: World Mythology and Masterpieces of World Literature

113823 Senior English: Reader's Choice and Masterpieces of World Literature

110611 AP Language/Composition

110700 AP Literature

All seniors are required to take one semester of Masterpieces of World Literature and one semester of a senior English elective. This does not apply to students taking AP Literature or AP Language/Composition.

Masterpieces of World Literature

This course is a combined study of literature and composition. The course material includes traditionally studied literature in translation from major world cultures and civilizations. Students will demonstrate competencies in writing, reading, listening, speaking, thinking, and using research technology.

113623 Senior English: Modern Short Stories from Around the World and Masterpieces of World Literature (12)

1 Year, 1 Unit

This course includes the combined study of translated short stories and composition. Cultures represented are Latin American, Chinese, Japanese, Indian, and African. The course is intended to add a contemporary view of world literature to the traditional one studied in Masterpieces of World Literature. Students will demonstrate competencies in writing, reading, listening, speaking, thinking, and using research technology.

113723 Senior English: World Mythology and Masterpieces of World Literature (12)

1 Year, 1 Unit

This course includes the combined study of literature and composition. The literature to be studied includes works which emphasize the role of myth in understanding other cultures and ways in which ancient stories are revealed in modern literature. Students will demonstrate competencies in writing, reading, listening, speaking, thinking, and using research technology.

**113823 Senior English: Reader's Choice and
Masterpieces of World Literature (12)
1 Year, 1 Unit**

Reader's Choice works toward breadth and depth of reading, building the student's reading repertoire, and connecting reading to writing, listening, speaking, and other life experiences. Students will choose their own selections to read for the purposes of 1) information, 2) entertainment, 3) critical analysis and evaluation, and 4) social interaction. Students will demonstrate progress with a writing and literature portfolio. This course incorporates a weekly service-learning reading tutorial with Jefferson Elementary students.

**110611 AP Language/Composition (11, 12*)
1 Year, 1 Unit**

Prerequisites: A 3.5 GPA or higher or written approval of spring semester English teacher attached to CAP registration, AP contract submitted by May 24 and summer assignment due on 1st day of class.

AP Language and Composition is a yearlong course in writing for academic purposes. Students will develop their own writing processes and styles by completing a variety of essay assignments, including a five-week research paper during the spring semester. They will study the semantic, structural, and rhetorical resources of language as well as the history of English. Students can expect one hour of homework per night.

* Students who take APLAC as seniors will read alternate titles for major works since they have already read the required junior selections.

**110711 AP Literature (12)
1 Year, 1 Unit**

This course is designed to survey challenging works of poetry, fiction, drama, and nonfiction representative of the different periods of Western intellectual history. The perspective of the course will be broadly humanistic. The course seeks to develop in the student a generalist's knowledge of Western intellectual tradition and the ability to apply that knowledge in analyzing and writing about literature. **Students will be required to complete a summer reading assignment.**

**001133 Literary Magazine (11, 12)
1 Year, 1 Unit**

Prerequisite: Completion of the application process described below
Elective Credit Only

Staff members will publish *Connotations*, the high school's literary magazine and two children's magazines. They will participate in all phases of the production process: writing, editing, evaluation, design, promotion, and sales. Fund-raising projects and production deadlines will demand after-school hours. Enrollment in AP Language and Composition is advised for all staff members.

Students interested in being on the Literary Magazine staff must pick up an application in Room 2308. Staff will review applications and select students to interview. Students will be notified of appointments for interviews. Students will be notified by letter whether or not they are selected for staff.

ESL – COURSES FOR LIMITED ENGLISH SPEAKERS

115035 English as a Second Language I 1 Year, 1 Unit

Prerequisite: Score of 1 on LAS Exam (Language Assessment Scales)

This course introduces the student to basic conversational English in practical social contexts. Some grammar is emphasized in relation to developing reading and listening comprehension skills. Newspaper and magazine articles, short stories, fiction and non fiction, and poetry will be used to improve the students' scholastic vocabulary.



道

115135 English as a Second Language II 1 Year, 1 Unit

Prerequisite: ESL I and score of 2 or 3 on LAS Exam (Language Assessment Scales)

ESL II is a more advanced level of ESL I. The focus is upon developing a more varied vocabulary through more intensive study of grammar, idiomatic usage and reading & writing. Periodicals as well as fiction and non-fiction and poetry will be used to improve reading comprehension and increase the students' range of expression and ability in writing. Short presentations will emphasize organizational and speaking abilities. This course will also continue the improvement of language skills needed in the students' other courses.

115235 English as a Second Language III 1 Year, 1 Unit

Prerequisite: ESL II and score of 4 on LAS Exam (Language Assessment Scales)

ESL III is a more advanced level of ESL II. The purpose will be to prepare the students to make the transition from the ESL umbrella to regular English class.

FAMILY AND CONSUMER SCIENCES

823033 Food and Nutrition (10, 11, 12)
1 Semester, ½ Unit
Fall or Spring

This course focuses on the development of skills needed to select, prepare, and serve food that meets nutritional needs of individuals and families. Upon completion of the class, students should be able to apply nutritional practices that will have a positive effect on their health. Emphasis in this course is given to the development of competencies related to the following: nutrition, weight control, kitchen organization, equipment, safety and sanitation, menu planning, serving and eating food, food preparation, eating away from home, and career opportunities.

823133 Housing and Interior Design (10, 11, 12)
1 Semester, ½ Unit
Fall or Spring

Housing and Interior Design focuses on personal and family housing needs, and options for meeting those needs. Emphasis is given to housing options; trends in housing; financial and legal commitments related to housing; home construction; art principles as applied to housing and interiors; selection, care, and arrangement of home furnishing and appliances; and energy conservation.



823233 Nutrition for Life (10, 11, 12)
1 Semester, ½ Unit
Fall or Spring

Nutrition for Life emphasizes the interaction of nutrition, foods, sports and exercise for lifelong fitness and well being of individuals and families. The course focuses on nutrition as it relates to wellness, sports nutrition and food choices throughout the life span.



823333 Parenting (10, 11, 12)
1 Semester, ½ Unit
Fall or Spring

This course is designed to provide students with the opportunity to develop the skills needed for successfully working with children, primarily dealing with the concerns of adults during pregnancy and early parenting years.

823433 Family Dynamics (10, 11, 12)
1 Year, 1 Unit

Family Dynamics is an in-depth course that explores dynamics of family life, one's image, life relationships, responsible parenting, crisis management, resource management, civic responsibility, food and fitness, housing, career planning, and marriage preparation skills.

823633 Money Management (10, 11, 12)
1 Semester, ½ Unit
Fall or Spring

This project based course is designed to help the consumer. Student learning is connected to real life situations through the study of the following topics: Family Finances and Resources, Investment Portfolios, and Budgeting. Other topics include managing change, exploring resources, and management in the world of work.

FAYETTEVILLE ADVANCED SPATIAL AND SERVICE TECHNOLOGY CENTER

Who should take a FASST class? Any student who enjoys helping the community and wants to know more about technology in a safe, self-paced environment. **Students in FASST must be self-motivated and able to keep focused on their projects.** FASST is designed for any level of student from the very basic to the high tech guru. The FASST classroom is designed to help the student prepare for real world problem solving while giving them a safe area to explore their ideas without real world consequences. The materials in the classroom are designed to build academic, technical, and social skills needed for life outside the classroom environment.

Students who take FASST will have the opportunity to learn what is being done in the workplace using current technology. Students also build job skills and creative thinking skills, develop community relationships, and demonstrate the ideas and principles learned in the FASST classroom.

**For more information visit the FASST website:
<http://fasst.fayar.net>**

001733 FASST I: Fayetteville Advanced Spatial and Service Technology Center (10, 11, 12)
1 Year, 1 Unit
Credit: Elective

This technology-based course provides students with the opportunity to develop solutions for a wide range of problems currently affecting our school and local community. Each student will be responsible for helping the school and community in real world problem solving. Students will establish individual projects and work towards completing the project goals. Students also will have group projects to develop teamwork and solve problems too complex for individual projects. Students will accomplish these goals through the use of numerous in-class tools, including Microsoft Office, Photoshop, Geomedia, Solid Edge, 3D Graphics Software, Front Page, Global Information Software, and Global Positioning Software.

001833 FASST II: Fayetteville Advanced Spatial and Service Technology Center (10, 11, 12)
1 Year, 1 Unit
Prerequisite: FASST I
Credit: Elective

Students in this course help teach and train students enrolled in the FASST I classroom as well as work on more complex community based projects. FASST II students should have a technical understanding of software used in the classroom and work to help others develop their skills. Students in FASST II will be responsible for team building, project coordination, and organizing group projects. Students who take this course learn to help others in the classroom while developing leadership and organizational skills needed for the FASST III community environment.

001933 FASST III: Fayetteville Advanced Spatial and Service Technology Center (10, 11, 12)
1 Year, 1 Unit
Prerequisite: FASST II with Instructor approval
Credit: Elective

FASST III is a course designed to extend and apply the knowledge gained in the FASST I and II classroom. FASST III students will assume various managerial roles in the classroom. Students who enroll in this course will be responsible for team based projects as well as completing the more complex problems that may arise in the project. Students in this course will focus mainly on working in the community and being a liaison between the team members and community leaders. FASST III students must be highly motivated, responsible, and dedicated to providing positive relations in the community.

FAYETTEVILLE CAREER ACADEMY

A Career Academy is a college preparatory program that links academics with real careers within our community. It is built around a career theme and introduces all aspects of a career to better prepare students for postsecondary learning and a wide spectrum of career options. A Career Academy provides integrated curriculum among the four core academic areas of English, science, social studies, and math, and links these areas with a career theme. Currently, there are two academies that include a broad spectrum of career foci: The Health and Human Services Academy that includes pathways in the medical technology, and pre-engineering (new for 2003-2004).

The teachers in the core academic classes, as well as the career focus teacher, work closely with the community business leaders to provide a variety of ways to align the curriculum content with the careers available in our community. Through field trips, guest speakers, hands-on learning, job shadowing, and internships, students can gain a better understanding of what careers are available to them within our community. Core academic classes for Career Academy students will be determined through the CAP process.

Students entering a Career Academy are required to take the “Keystone” class during their sophomore year, either during the fall or spring semester. This class is designed to transition incoming students into the high school and the Career Academies. Keystone topics include Getting to Know Fayetteville High School, Communication Skills, Career and College Awareness, Study Skills, Time Management, and Goal Setting Strategies. Guest speakers from the community and professional world will begin introducing students to a variety of careers and the skills and attitudes needed to be successful. In addition, sophomores will take the introductory career focus class for their chosen Career Academy.

All Career Academy students are also required to take the “Capstone” class either the spring semester of their junior or the fall semester of their senior year. This class is designed to help juniors or seniors transition out of high school. Topics included Culminating the High School Experience, Job Shadowing, Planning the Next Step, Finding Financial Resources, Resumes and Portfolios, Interview Skills, School & Career Investigations, and Application Assistance.

The following areas of study are available in the Career Academies:

Health & Human Services

Medical Science Technology-Introduction
Medical Procedures
Medical Terminology
Human Body in Health & Disease
Clinical Internship
Medical Specialization/Work-Based Learning

Business & Technology

Management
Office Administration
Accounting
Banking
Desktop Publishing
Multimedia
Programming
Marketing
Computer Repair
Introduction to Engineering Design
Computer Integrated Manufacturing
Principles of Engineering
Digital Electronics
Engineering Design & Development

FOREIGN LANGUAGE

720133 Narrative French

1 Year, 1 Unit

Prerequisite: None

Note: This class does not meet the 2-year foreign language Honor Graduation requirements for students graduating in 2003 and following.

This course is designed to introduce students to spoken French and the French culture. Students will learn to understand and respond to spoken commands in French through the *Total Physical Response* approach of language learning. Speaking French will be taught through storytelling with the use of American Sign Language, songs, and phrase memorization. There will be less emphasis on grammar studies and writing skills than in the college prep French I course. Cultural study will include an introduction to Paris and the regions of France, French films, art, and cuisine, and exposure to African countries where French is spoken.

720233 French I (10, 11, 12)

1 Year, 1 Unit

French I is a basic introduction to the five skills of language: speaking, listening comprehension, reading, writing, and culture. Students learn elementary grammar skills and vocabulary pertaining to such topics as days of the week; months of the year; numbers; telling time; family; ordering in a café; daily activities; likes and dislikes; descriptions of people, things, and places in a French city; buying clothes; and leisure time activities. Emphasis is placed on the application of all grammar and vocabulary skills to speaking and understanding French, as well as writing well-organized paragraphs in the language. Grades are based on test performance, written and oral assignments, and oral interviews. A minimum of 20 minutes of homework per night is required.

720333 French II (10, 11, 12)

1 Year, 1 Unit

Prerequisite: French I

French II is a continuation of French I with emphasis on the five language skills: speaking, listening comprehension, reading, writing, and culture. Grammar study is more complex, and vocabulary is expanded to include such topics as school, professions, meals, food, shopping, entertainment, sports, health, and house and home. Emphasis continues to be on applying all grammar and vocabulary skills to conversation and to writing well-organized compositions in French. Class time is used to practice speaking and listening skills; therefore, students must assume more responsibility for mastery of text material at home. Grades are based on written or oral

assignments, performance on tests, and oral interviews. Thirty minutes per day for homework is expected for the average student. This course is recommended for students who have recorded grades of a “C” or better in French I.

720433 French III (10, 11, 12)

1 Year, 1 Unit

Prerequisite: French II

The emphasis in this course is refinement of the five language skills: speaking, listening comprehension, reading, writing, and culture. Grammar and vocabulary study is continued with an emphasis on oral and written expression. Students read short stories, poetry, and excerpts from the texts; give oral presentations; and watch French films. Class discussion in French is a large part of the students’ grade as well as test performance and written homework. The class is conducted primarily in French. Cultural topics include French history, modern art, music, and provinces. This course is recommended for students who have recorded grades of a “C” or better in French II.

720631 AP French IV

1 Year, 1 Unit

Prerequisite: French III

AP French IV is the culmination of the French program at Fayetteville High School. Students complete the study of French grammar, and are prepared to take the AP French language test in May. Students further develop their language skills by the use of the Internet for research and presentations, by the study of French films, as well as by reading poetry, short stories, and novels in French. Emphasis is put on XIXth Century authors such as Maupassant, Baudelaire, and Rimbaud, as well as the existentialist works of Sartre and Camus in the XXth Century. Cultural topics include the French resistance during WWII, and French-speaking Africa. The class is conducted entirely in French. Forty-five minutes minimum of homework per day will be required. Compositions are assigned weekly. Grades are based on written and oral assignments, classroom discussions, and performance on tests.

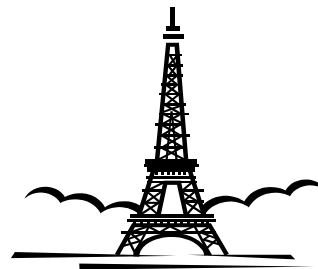

GERMAN:

730733 Narrative German 1 Year, 1 Unit

Prerequisite: None

Note: This class does not meet the 2-year foreign language Honor Graduation requirements for students graduating in 2003 and following.

This class is for students who want to learn basic conversational German without emphasis on grammar studies. The class will emphasize the conversational skills that students will need to function at a basic level in German. The class will be taught primarily through storytelling, communicative situations, songs, and projects.

730833 German I (10, 11, 12) 1 Year, 1 Unit

German I is an introduction to the basic grammar and vocabulary of the German language. Students will become aware of basic cultural differences in connection with the unit themes: sports and activities, family and the home, school, shopping for clothing, ordering food and drink, and responsibilities. The student is expected to take notes and participate in all listening, speaking, reading, and writing activities. Daily practice and review are necessary for success. Grades are based on test and quiz performance, class participation, homework, projects, and oral interviews. A minimum of fifteen minutes of homework will be required each night. This course is recommended for students who have recorded grades of “C” or better in English.

730933 German II (10, 11, 12) 1 Year, 1 Unit **Prerequisite:** German I

German II is a continuation of the presentation of the basic grammar of the language and culture not covered in German I. In the classroom listening, speaking, reading, and writing skills are further developed with the emphasis on communicative activities. Students must assume more responsibility for mastery of vocabulary than students taking German I. A minimum of twenty minutes of homework per night is required. Grades are based on test and quiz performance, homework, class participation, projects, and oral interviews. This course is recommended for students who have recorded grades of “C” or better in German I.

731033 German III (10, 11, 12) 1 Year, 1 Unit **Prerequisite:** German II

German III is a pre-AP course. It is a review of the basic grammar and language and an introduction to advanced structures, poetry, short stories, essays, news articles, and songs. There is increased emphasis on developing reading, writing, and translation skill. Class discussion is primarily in German. Students will increase awareness of cultural differences in connection with the unit themes. Attendance at “Stammtisch” is suggested. A college text is used in this course.

731231 AP German IV (10, 11, 12) 1 Year, 1 Unit **Prerequisite:** German III

German IV is intended for students with a strong background in German who wish to develop their written and oral communication skills. It reinforces the development of vocabulary and grammatical structure, the understanding of spoken German in various conversational settings, the reading of non-technical writings without the use of a dictionary, and the expression of accurate and fluent oral and written German. The class is conducted primarily in German. Attendance at “Stammtisch” is suggested.



SPANISH:

711433 Spanish for Spanish Speakers

1 Year, 1 Unit

Prerequisite: The student's first language must be Spanish

This course is for students whose first language is Spanish who need to fine-tune their reading and writing skills. The class will work on proper grammar skills and writing techniques. It will also improve reading skills, vocabulary development, and spelling. This is not a class in conversational Spanish.

711533 Narrative Spanish

1 Year, 1 Unit

Prerequisite: None. For students with little or no previous Spanish study or who do not have Spanish I credit.

Note: This class does not meet the 2-year foreign language Honor Graduation requirements for students graduating in 2003 and following.

This class is for students who want to learn basic conversational Spanish without emphasis on grammar studies. The class will emphasize conversational skills and storytelling, with some attention given to reading and writing. The class will be taught mainly by storytelling with the use of American Sign Language, songs, and project. Students will be speaking Spanish immediately with a minimum of outside work. Cultural emphasis will highlight the Caribbean.

711633 Spanish I (10, 11, 12)

1 Year, 1 Unit

For students with little or no previous Spanish study

Note: This course is recommended for students who have recorded grades of a "C" or better in English.

Spanish I is an introduction to the basic grammar and vocabulary of the Spanish language, including Hispanic culture, with an emphasis on Mexico. The student is expected to take notes and participate in all speaking, listening, reading, and writing activities. Oral presentations will be required for each unit. There is an introduction to storytelling using American Sign Language. Daily memorization, practice, and review of past lessons will be necessary for success.

711733 Spanish II (10, 11, 12)

1 Year, 1 Unit

Prerequisite: Spanish I

Note: This course is recommended for students who have recorded grades of a "C" or better in Spanish I.

Spanish II is a continuation of the presentation of the basic grammar and vocabulary of the language. Discussion of Hispanic cultures emphasizes Central and South America. Listening, speaking, reading and writing skills are developed with emphasis on communicative activities. Students are taught by using storytelling with American Sign Language for oral proficiency and by using reading, writing, and listening exercises. Grades are based in quizzes, chapter tests, and oral presentations.

711833 Spanish III (12, 11, 12)

1 Year, 1 Unit

Prerequisite: Spanish II

Spanish III is a proficiency-based course designed to introduce advanced structures through poetry, short stories, news articles, songs, and conversation. Class is conducted in Spanish; students are expected to speak and participate. Total Physical Response Storytelling (TPRS) is the method used to increase both listening and speaking proficiency. *Destinos*, a video series, is part of the listening curriculum. The culture of Spain is emphasized, although materials read will come from throughout the Spanish-speaking world. This is a participation class. Students will also have homework packet projects to complete each quarter designed to work the current class' vocabulary.

711933 Spanish IV (10, 11, 12)

1 Year, 1 Unit

Prerequisite: Spanish III

Students work with the language to develop the following skills: the ability to express and defend points of view in written composition and oral expression, comprehension of oral and written materials in a variety of media, and the ability to interpret unfamiliar words and idioms. The video listening series, *Destinos*, is used for improving listening proficiency. Students are expected to write daily in Spanish, building a large working vocabulary and developing a solid knowledge of grammatical forms. Thirty minutes of homework per night should be expected. The class is conducted in Spanish. (Students will be graded on a 4-point "A" scale.) Speaking proficiency will continue to be developed through TPRS (Total Physical Response Storytelling) and daily participation is expected.

712031 AP Spanish Language IV (10, 11, 12)

1 Year, 1 Unit

Prerequisite: Spanish III

This course prepares students for the AP Spanish Language exam given in May. Course curriculum is the same as that of Spanish IV, but students will also be required to do the extra outside grammar and written preparation needed to take the AP exam. An additional fifteen to twenty minutes of homework will be required. (Students will be graded on a 5-point "A" scale.)

712131 AP Spanish Literature V (10, 11, 12)

1 Year, 1 Unit

Prerequisite: Spanish IV or AP Spanish Language IV

This course prepares students for the AP Spanish Literature exam given in May. Students will build their skills in written composition and oral expression. They will study the works of the five AP authors in Spanish. Students will learn how to compare and contrast the works of the same authors. They will learn the components of literary analysis which they will then apply to the various works that have been read. The class is conducted in Spanish. Students will be required to complete a summer reading assignment before taking the course.

HEALTH EDUCATION

520133 Health I (10, 11, 12) **1 Semester, ½ Unit** **Fall or Spring**

This course is designed for students who wish to complete the basic health requirements in one semester. Course content is based on a multidimensional approach to wellness as in Comprehensive Health. Topics are accelerated to cover all health standards in one semester.

523033 Comprehensive Health (10, 11, 12) **1 Year, 1 Unit** **Students must take both semesters to receive health credit for graduation.**

This course is designed for those students who wish to augment their knowledge of health by field trips, guest speakers, community projects, and student wellness groups. Content is based on a multidimensional approach to wellness. Topics include: health appraisals, holistic health, health careers, stress management, mental-emotional health, suicide intervention, aging, death and dying, cardiovascular disease/fitness, nutrition, weight control, drugs/alcohol, family life, child abuse, rape/incest, CPR, and first aid.

520233 Health & Fitness Awareness **1 Year, 1 Unit (½ unit Health, ½ unit P.E.)**

This course is designed for those students who desire to complete both their physical education and health education requirements in one course. Its purpose is to help students become aware of their total fitness needs and the concepts of total wellness related to their personal health. Class instruction will be divided equally between health and physical education. Students will be involved in hands-on projects in the lab, individual fitness programs, recreational activities such as scuba diving, fencing, ping pong, and other life-time activities. Students will have the opportunity to become certified in life-guarding, first aid/CPR, and scuba diving.

Please note the following:

Students wishing to enroll in Sports Medicine must complete the application process below:

- 1) Obtain an application from Dr. Williams in room 2405.
- 2) Fill out the form and return it in person to Dr. Williams.
- 3) Attend a brief meeting to discuss the program and student responsibilities.

For more information, call Dr. Williams at 444-3050, extension 114.

520413 Sports Medicine (11, 12) **1 Year, 1 Unit**

Prerequisite: Health, Biology, and completion of the application process described previously. A current TB skin test card. Students must have been enrolled in the 1st semester class to be eligible for the 2nd semester.

This course is designed for those students who are interested in learning about sports medicine, exercise science, and the medical or allied health professions. Students will have hands-on experience with the following topics/equipment: electrocardiography, blood chemistry, electronic cardiovascular stress testing, medical software, radiology, strength testing, percentage of body fat, surgical observation, nutritional analysis, anatomy/physiology, image analysis, and video production.

494129 Introduction to Medical Professions Education I (10, 11, 12) **1 Semester, ½ Unit** **Fall only**

This is the first part of a 2-semester course designed to provide students with basic information and skills needed for a career in a health care field. **In order to be a completer in Medical Professions Education you must complete both semesters.** Emphasis is given to the development of competencies based on the Arkansas Frameworks, which include:

- Career, Technical and Professional Organization
- Health Care Delivery Systems
- Professionalism, Ethics & Legalities of Medicine
- Medical Math
- Human Growth and Development
- Geriatric Care – Includes regular interactive visits to selected nursing homes
- Complementary/Alternative Healing Techniques
- Job Shadowing Experience

494132 Introduction to Medical Professions Education II – Medical Terminology (10, 11, 12) **1 Semester, ½ Unit** **Spring only**

This is the second part of a 2-semester course designed to provide students with basic information and skills needed for a career in a health care field. **In order to be a completer in Medical Professions Education you must complete both semesters.** Medical Terminology assists students in developing the language used for communication in the health care profession.

494128 Medical Procedures (10, 11, 12)
1 Year, 1 Unit

Students develop specific skills needed in the health care professions. **In order to be a completer in Medical Procedures you must complete both semesters.** Emphasis is given to the development of competencies based on the Arkansas Frameworks which include:

- Basic Infection Control
- Safety
- First Air/CPR/AED
- Vital Signs
- Dental Science Skills
- Nurse Assistant Skills
- Medical Office Assistant Skills
- Physical Therapy Techniques
- Animal Health Care
- Intro to Insurance Coding
- Internship in selected career focus
- Capstone project



494125 Human Anatomy and Physiology for Medical Professions (10, 11, 12)
1 Year, 1 Unit

This is a one-year course that focuses on anatomical and physiological systems of the body as well as the diseases of those systems. **In order to be a completer in Medical Professions Education you must complete both semesters.**

Coach Gebhart and his Health I classes are currently using the Internet to research dietary guidelines and nutritional information.

Coach Kretschmar is using the *Tai Bo* video in her aerobic classes for a part of their individualized fitness programs.

Dr. Williams and the Exercise Physiology classes are utilizing image analysis to study different sport skills and then trying to teach a student who has no experience with this particular skill. In his Health & Fitness Awareness classes they are studying stress management and participating in pickle ball, volleyball, and weight lifting.

A FHS student, under the direction of Mr. Whitaker, is helping develop a health education web page to display information about the faculty and objectives of the health and physical education department.

HUMANITIES

001433 Greek and Roman Classics (11, 12)

1 Year, 1 Unit

Elective Credit Only

This elective course will focus on the Latin language but will also broadly explore the history, philosophy, literature, and culture of ancient Greece and Rome. Writers like Homer, Plato, Sophocles, Aristophanes, Virgil, Ovid, Lucretius, and Tacitus, among others, will be studied. Much of the reading of ancient sources will have to be done in translation, but the goal is that by the end of the year students will be reading at least a little real Latin and, possibly, some Greek. To do well in this course, the student will want a genuine interest in the time and place and a particular enthusiasm for learning Latin. No previous knowledge is necessary.

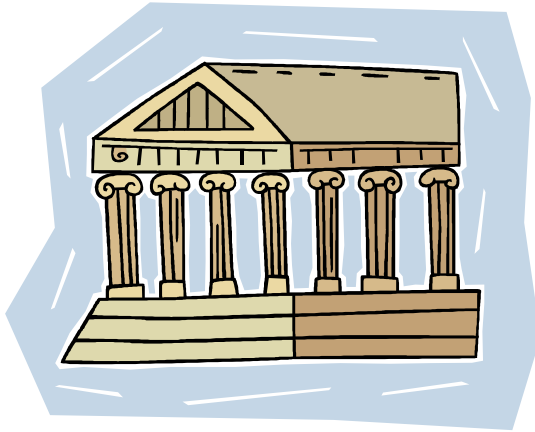

111823 Asian Studies (11, 12)

1 year, 1 Unit

Elective Credit Only

This course gives students the opportunity to study a number of Asian civilizations by investigating their societies and cultures, including the countries of the Middle East, India, China, Japan, and Tibet. Though some class time will involve films and music, students will read widely and be expected to participate in class discussions. Coursework will include writing a number of essays.

421623 Cultural Studies (12)

1 Year, 1 Unit

The course is designed to emphasize the interdependence and continuity of images, values, and ideas in American cultural history as documented by visual texts, i.e. film. The course is multidisciplinary and includes study units on law, science and technology, conformity and conflict, the public aspects of electronic media and its impact on policy and opinion, and various other themes. The seminar format is used, and students are responsible for readings and projects. Writing skills are stressed and essays are required. The course is for students interested in a holistic approach to the humanities within a nontraditional context. Although similar classes exist at the university level, the class is not restricted to college-bound students. All are encouraged to participate because the interaction of groups with diverse intellectual achievements and academic interests is vital to an integral educational experience.



JOURNALISM

651433 Photography I (10, 11, 12)
1 Semester, ½ Unit
Fall or Spring
Fine Arts Elective

Students must own or have frequent access to a 35mm camera for the entire semester. The course is a basic study of photography which includes: 1) the use of manual 35mm cameras, 2) developing and printing black and white film, 3) visual elements of composition, 4) history of photography, and 5) law as it applies to the publication of photographs. Chemicals to develop film are provided. A manual 35mm camera is preferred, but an automatic camera is acceptable. Students are expected to spend **approximately \$20 on film** and all students will spend about **\$7 on photo paper** for their projects. Students must provide film (4-5 rolls) and photographic paper. A \$10 chemical fee and 1 roll of paper towel is required.

651533 Photography II - Photo Staff (10, 11, 12)
1 Year, 1 Unit
Prerequisite: Photo I or previous experience developing and printing film

Students must own or have use of a 35mm camera on a daily basis. Photo staff members are responsible for all photographs for the school newspaper and yearbook. Advanced picture-taking and darkroom skills are taught. Photographing people, groups, sports, and school events; negative filing and organization; and darkroom maintenance are among the skills developed. A photo fee of \$10 per semester is required. **Deadlines are strictly enforced.**

130133 Yearbook (10, 11, 12)
1 Year, 1 Unit
Prerequisite: Journalism I, teacher selections, and student application required. Please see Mr. Teague for an application to fill out. Each student's application will be reviewed by the course instructor.

Staff members will publish *The Amethyst*, the school's yearbook. Advanced methods and techniques for writing, editing, organizing, designing, and financing yearbooks are taught. A willingness to sell advertising and to learn to use computers is expected. **Out-of-class time may be required to meet yearbook deadlines. Deadlines are strictly enforced.**

130233 Journalism I (10, 11, 12)
1 Semester, ½ Unit
Fall

This is the **prerequisite** for FHS newspaper and yearbook. This class is designed to provide basic writing and design skills needed for newspaper and yearbook. Other skills taught include headline and outline writing. Lessons on ethics of journalism and newspaper history are also included. **At least four writing assignments are required. Deadlines are extremely important.**

130433 Newspaper (11, 12)
1 Year, 1 Unit
Prerequisite: Journalism I, teacher selections, and student application required. Please see Ms. Yates for an application to fill out. Each student's application will be reviewed by the course instructor and a review board of students.

Members of this class publish *The Register*, the school's newspaper. Advanced methods and techniques for writing, editing, organizing, designing, and financing a newspaper are taught by producing the newspaper. A willingness to learn to use computers is expected. **Out-of-class time will be required to meet deadlines. Deadlines are strictly enforced.**

The Amethyst, the FHS yearbook has won numerous state and national awards for journalistic excellence.

FHS newspaper, *The Register*, has won the prestigious All-Arkansas award for journalism excellence from the Arkansas Scholastic Press Association three years in a row ranking it as one of the top high school newspapers in the state.

FHS newspaper staffers attend the Ark. Scholastic Press convention each spring in Little Rock to compete in staff and individual competitions, winning writing, design and editing awards along the way.

Some Photo I classes regularly have their work displayed in the FHS library.

Some Journalism I students have their class newswriting articles published in the FHS Register.

The Register staff won a Fayetteville Education Foundation grant several years ago to upgrade computer equipment in the newsroom.

MARKETING

* Students may exhibit their knowledge and skill in various marketing operations through participation in the Distributive Education Clubs of America (DECA), an organization of marketing students. Junior and Senior students may also receive additional credit by enrolling in the Marketing Apprenticeship program which replaces Marketing OJT I and OJT II and Marketing Management OJT I and OJT II.

888133 Retailing (10, 11, 12) *
1 Semester, ½ Unit
Fall Only

This course is an introduction to the various aspects of running a retail business. Topics may include: selling, buying, merchandising, sales promotion and advertising, e-business, business operations, and retail management.

888033 Advertising (10, 11, 12) *
1 Semester, ½ Unit
Spring Only

Experience the advertising side of marketing. This course will include a study of marketing research, determining market segments for promotion purposes, and preparing ads for print and broadcast media. Students also will evaluate ads seen every day in print and internet advertising for effectiveness in reaching the target audience for the product being advertised.

492044 Salesmanship (10, 11, 12)
1 Semester, ½ Unit
Fall only

Salesmanship is a one-semester course designed to inform students about specific selling techniques and attitudes necessary to become a successful salesperson. The course focuses on serving customers and helping them make wise buying decisions. Emphasis is placed on the importance of human relations in selling, the functions performed by salespeople, and the buying/selling process.

492019 Fashion Merchandising (10, 11, 12)
1 Semester, ½ Unit
Spring only

Fashion Merchandising is a one-semester course designed to offer an overview of the fashion industry. It provides the background for a wide range of careers available in the different levels of the fashion industry. Emphasis is given to the historical development, textiles, production, international markets, accessories and fashion retailing and promotion.

888213 Marketing (11, 12) *
1 Year, 1 Unit

This course provides training in marketing and distribution utilizing classroom instruction and business simulations. Topics studied may include economics, selling, human relations, merchandising, business operations, and sales promotion and advertising.

888523 Marketing Management (12) *
1 Year, 1 Unit
Prerequisite: Marketing, Retailing, or Advertising

This course is a continuation of Marketing with emphasis on retail management and entrepreneurship. Students will participate in product design, product production and assembly, advertising, display, marketing, profit/loss margins and the economic infrastructure.

Marketing/Retailing Apprenticeship (11, 12)

The Marketing/Retailing Apprenticeship program is designed to prepare high school juniors and seniors for careers in the Marketing/Retailing area. Students will have an opportunity to interview for jobs at appropriate work sites where they will work part of each day. Students can earn ½ credit (180 work hours per semester or 10 hours per week), or 1 credit (270 work hours per semester or 15 hour per week), or 1.5 credits (360 work hours per semester or 20 hours per week). Students enrolled in apprenticeships must also enroll in related classes recommended by their apprenticeship teacher. (Some employers require drug testing as a condition for employment.)

MATHEMATICS

To progress through the study of mathematics, prerequisites should be met for each course. A letter grade of less than a “C” for a semester or nine weeks could indicate deficiencies at the next level. Students with a “D” in their last mathematics course have not demonstrated evidence of their understanding of the mathematics that they had been studying. This should be a MAJOR point of discussion as plans are made for the next mathematics course. A student who has scored below basic on the End of Course examination has shown no evidence of the potential for success in the next course of study. It is recommended that students repeat courses for the purpose of improving understanding of concepts prior to proceeding to the next level.

For graduation, at least three units of mathematics are required for all students. The Arkansas Challenge Scholarship requires four units of math. In order to meet unconditional admission to the University of Arkansas the fourth year of math will be required beginning with the freshman class of 2004. Students are strongly encouraged to take mathematics their senior year. The success rate in college is significantly higher among those students who study mathematics every year in high school.

The mathematics classes require the use of a TI graphing calculator. FHS has a leasing program for these graphing calculators.

| | | | |
|----------------|-----------------------|--------------------------------|---------------------|
| Level 1 | Algebra I | Honors Algebra I | |
| Level 2 | Applied Geometry | Geometry | Honors Geometry |
| Level 3 | Algebraic Connections | Algebra II | Honors Algebra II |
| Level 4 | Algebra II | College Prep Algebra with Trig | Trig/Analysis |
| Level 5 | Pre-calculus | AP Statistics | AP Calculus AB & BC |

- One semester options after Algebra II include: College Prep Algebra, Trigonometry, Finite Math and College Algebra.
- For a complete picture of the math path and math course offerings for grades 10-12, see Appendix F.

230333 Algebra I (10, 11, 12)

1 Year, 1 Unit

Prerequisite: Foundations of Algebra

Students will develop understanding of and skills with: the language of algebra; the use of properties of equality to solve linear and quadratic equations and inequalities; concepts of functions, relations, and patterns; the use of tables and graphs to represent data, make predictions, use simple matrices, use and apply linear, quadratic, and exponential functions; and polynomial operations and factoring of polynomials. Upon completion of both semesters of this course, students will take the End of Course exam.

Forty-six students took the AP Calculus AB exam in 2002 and all 46 passed with a 3, 4, or 5. In Calculus BC, 12 of the 13 students taking the AP exam passed with w 3, 4, or 5 and 7 of these made a 5. The AP Calculus exams test the complete spectrum of math skills studied throughout high school. Therefore, this achievement is evident of the strength of the entire math program at FHS.

240433 Applied Geometry (11, 12)

1 Year, 1 Unit

Prerequisite: Algebra I and recommendation of teacher

Applied geometry will consist of concepts focused on, but not limited to, geometric problem solving, lines and angles, two and three dimensional shapes, ratios and proportions, and scale drawings. Skills will be acquired in right triangle relationships including the Pythagorean Theorem, trigonometric functions, coordinate geometry, and transformational geometry. Upon completion of both semesters of this course, students will take the End of Course exam.

Note: Applied Geometry does not fulfill the geometry requirement for graduating honors.



240533 Geometry (10, 11, 12)**1 Year, 1 Unit****Recommended:** “C” or better in Algebra I

In this course, concepts are introduced visually, analytically, inductively, and deductively. Students will use the tools of geometry to perform investigations and learn by doing. Skills will be acquired in critical thinking, problem solving, properties of geometric figures, parallel and perpendicular lines, coordinate geometry, Pythagorean Theorem, area and volume, as well as compass and straightedge construction of geometric figures. Upon completion of both semesters of this course, students will take the End of Course exam.

231033 Algebraic Connections (10, 11, 12)**1 Year, 1 Unit****Prerequisite:** Algebra I and Geometry

This course will cover advanced algebra topics from probability, statistics, functions and graphs, data collecting with and without technology, and other discrete mathematics topics. This course meets the third year math requirement for graduation. Students could choose to follow this course with Algebra II. Completion of the Algebra II course is recommended for students entering college.

230833 Algebra II (10, 11, 12)**1 Year, 1 Unit****Prerequisite:** “C” or better in Algebra I and Geometry

This course includes the study of both the real and complex number systems; coordinate geometry; relations and functions; rational and irrational expressions; polynomial (including linear and quadratic) functions; systems of equations and inequalities; data analysis; matrices; exponential and logarithmic functions.

230932 Honors Algebra II (10, 11)**1 Year, 1 Unit****Prerequisite:** 3.25 average in Algebra I and Geometry

This course is designed for students who have been successful in studying Honors Algebra I and Honors Geometry and who enjoy a challenge. Honors Algebra II is a more rigorous approach to topics in the Algebra II curriculum. Students will study a variety of functions: linear, quadratic, polynomial, exponential, logarithmic, and rational. Additional topics such as systems of equations and inequalities, matrices, statistics, complex numbers, and models for data are covered. Students planning to take AP Calculus should take this course to be sufficiently prepared.

Over the last five years FHS math students have received about 87% of all NW Arkansas region invitations for the ACTM math contest category of Trigonometry/PreCalculus.

253032 College Prep Algebra with Trigonometry (11, 12)**1 Year, 1 Unit****Prerequisite:** “C” or better in Algebra II

College Prep Algebra with Trigonometry is designed as a fourth year mathematics course. Students taking this course should have completed Algebra 2 (or its equivalent). Successful completion of the course prepares students for college algebra. Topics include numerical, algebraic, and geometric concepts. The course uses a functional approach through the use of technology. Specific topics include linear, quadratic, power, polynomial, rational, inequalities, exponential and logarithmic functions, trigonometric and circular functions, relations among the parts of a triangle, trigonometric identities and equations, and solutions of right and oblique triangles. Each topic will be explored graphically, algebraically, and numerically with the use of graphing techniques, algebraic manipulation, modeling numeric data, and analyzing data. This course provides an extensive range of broad topics that exceeds the Arkansas Mathematics Curriculum Framework.

253132 Trigonometry/Introductory Analysis (10, 11, 12)**1 Year, 1 Unit****Prerequisite:** Grades of “B” or better in Geometry and Algebra II. Students who do not meet this prerequisite should enroll in the College Prep Algebra with Trigonometry course.

This course examines trigonometric functions, their properties, periodic functions, complex numbers, vectors, identities, and inverses. The student will acquire skills in solving triangles with an emphasis on applications. In addition, the course will develop skills and techniques of mathematical analysis and provide an essential foundation for the study of calculus. Topics studied include coordinate geometry, inequalities and their graphs, functions, exponents, logarithms, polynomials, and vectors. Students who successfully complete both semesters with a grade of “B” or better in this course will be prepared for advanced studies in calculus.

251732 Precalculus (11, 12)**1 Year, 1 Unit****Prerequisite:** Trigonometry

This is a preparatory calculus course with elements of introductory analysis. Students who are not ready for AP Calculus but who plan to take calculus in the future should take this course. Concepts emphasized include functions and mappings, series and sequences, vectors, matrices, and applications. The student will develop skills in the solution of inequalities, curve sketching, solution of systems of equations, problem solving, probability, with an emphasis on technology.

253331 AP Statistics (11, 12)**1 Year, 1 Unit****Prerequisite:** “B” or better in Algebra II

This course is similar to a college level introductory course in statistics. It follows the course outline recommended by the College Board with major emphasis on exploratory analysis, planning a study, probability, and statistical inference. Students will work on projects involving hands-on gathering and analysis of real world data. Computers and calculators allow a deeper focus on the concepts of statistics. This course prepares students for the Advanced Placement Examination in Statistics. Studying statistics would be beneficial for students with interests in engineering, psychology, sociology, health science, and business.

251931 AP Calculus AB (10, 11, 12)**1 Year, 1 Unit**

Prerequisite: Honors Algebra II and no grade less than a “B” in any previous semester of Trigonometry/Analysis is strongly recommended. Students not meeting this prerequisite should enroll in Pre-calculus.

This course is an equivalent of college-level Calculus I and is based on College Board guidelines. The concepts developed are limits, continuity, derivatives, definite and indefinite integrals, and curve sketching. Much emphasis is placed on applications involving velocity and acceleration, rate of change, area, volume of solids of revolution, and maximum and minimum values.

252031 AP Calculus BC (11, 12)**1 Year, 1 Unit****Prerequisite:** Approval of Calculus instructor

This course is an equivalent of college-level Calculus II and is based on College Board guidelines. Extensions of Calculus AB topics are covered, as well as sequences and series, polar coordinates and parametric equations, vectors in the plane, integration of partial fractions, and first order differential equations.

Mu Alpha Theta, FHS’ mathematics club, provides public recognition of the superior mathematical scholarship of its members and promotes various mathematical activities. There are currently 68 members for the 2002-2003 school year.

251830 College Algebra – Math 1204***1 Semester, ½ Unit Elective Credit****(NWACC – 4 college credit hours)****Fall or Spring**

Prerequisite: All students will be required to have a 3.0 GPA and ACT of 19 in math or SAT of 460 in math.

College Algebra provides an overview of the fundamental concepts of algebra. Topics include linear and quadratic equations and inequalities; the Cartesian plane and graphing; using a graphing utility; functions, graphs, and models; polynomial and rational functions; exponential and logarithmic functions; systems of equations, inequalities and matrices.

252130 Finite Math – Math 2053***1 Semester, ½ Unit Elective Credit****(NWACC – 3 college credit hours)****Spring only**

Prerequisite: All students will be required to have a 3.0 GPA and ACT math of 24 or a grade of “C” or better in College Algebra

This is a survey and applications course in mathematics designed for business, life science, and social science students. Topics include a review of using a graphing utility, linear models, systems of linear equations, matrices, linear programming, the simplex method, set theory, probability, counting principles, statistics, and finance mathematics.

* College Algebra and Finite Math are Step Ahead enrollment courses offered by Fayetteville High School and Northwest Arkansas Community College (NWACC). Enrollment requirements for all Step Ahead courses are found on page iii of this book.

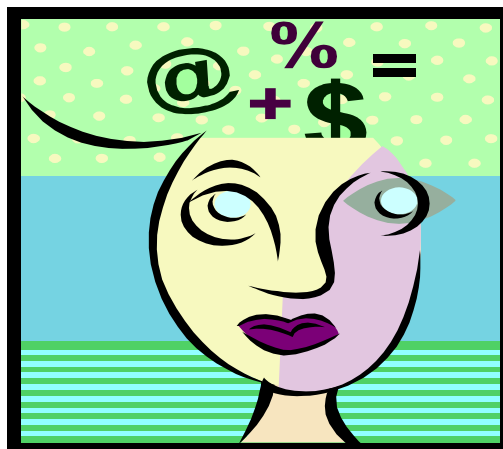

MUSIC

610133 Band (10, 11, 12) **1 Year, 1 Unit**

Prerequisite: Band in the previous semester. Students not meeting the prerequisite and students transferring to the district should contact the band director Barry Harper at 444-3050 ext. 127 for an audition appointment or more information.

Band offers students the opportunity to improve their musical ability on their instrument while participating in a large performing organization. The band participates in many mandatory concerts, contests, and performances throughout the year. In addition, students have opportunities to play as individuals and in small groups such as jazz ensemble and various honor bands.

610233 Music Theory (10, 11, 12) **1 Year, 1 Unit**

Prerequisite: Concurrent enrollment in band, choir, or approval of instructor.

Music Theory is a full year course designed to provide music students with fundamental written and Aural skills in preparation for their continuing music studies. These skills include the ability to translate sounds into musical notation (dictation) and the ability to translate musical notation into sounds (sight-singing). In addition, students will begin to acquire some of the basic language necessary for speaking intelligently and analytically about music and its structure. This course is designed for students who plan to continue with music at the college level. Students should also be concurrently enrolled in a music class (band or choir) or have an extensive musical background.

The Fayetteville High School Band recently marched in the 70th annual Hollywood Christmas Parade and received the "Spirit of Hollywood Award" for the band that best represents its high school, community, and state.

The FHS Band received national attention as the first Arkansas band to perform in the prestigious Macy's Thanksgiving Day Parade in New York City.

Consistently the FHS Band has received superior ratings in marching, concert, and sight-reading competitions.

620333 Concert Choir (10, 11, 12) **1 Year, 1 Unit**

Concert Choir is a mixed chorus that performs a wide variety of choral music. Students are given the opportunity to grow musically through daily rehearsals and by required participation in concerts and contests. Fund raising opportunities are provided to help defray the cost of uniforms. Uniform cost ranges from \$30-\$70.

620503 Select Men's Chorus (10, 11, 12) **1 Year, 1 Unit**

Prerequisite: Audition as described below *

Select Men's Chorus is composed mostly of sophomores that perform a wide variety of challenging music. Students are given the opportunity to grow musically through daily rehearsals and by participating in required events such as concerts, contests, and All-Region Choir auditions. Fund raising opportunities are provided to help defray the cost of uniforms. Tuxedo rental for the year is \$30.

620103 Select Women's Chorus (10, 11, 12) **1 Year, 1 Unit**

Prerequisite: Audition as described below *

Select Women's Chorus is composed mostly of sophomores that perform a wide variety of challenging music. Students are given the opportunity to grow musically through daily rehearsals and by participating in required events such as concerts, contests, and All-Region Choir auditions. Fund raising opportunities are provided to help defray the cost of uniforms. Purchase price for dresses ranges from \$50-\$70.

620233 A Capella Choir (11, 12) **1 Year, 1 Unit**

Prerequisite: Audition as described below *

A Capella Choir is an award-winning select mixed chorus that performs a wide variety of challenging music and is composed mainly of juniors and seniors. Students are given the opportunity to grow musically through daily rehearsals and by participation in required events such as concerts, contests, and All-Region Choir auditions. Fund raising opportunities are provided to help defray the cost of uniforms. Purchase price for dresses ranges from \$60-\$80. Tuxedo rental is \$30 for the year.

* Students wishing to enroll in choir who are new to the district or who are not currently enrolled in choir should contact the director, Dawnelle Fincher, at 444-3050, ext. 126, for an audition time.

ORAL COMMUNICATION/DEBATE/FORENSICS

120133 Oral Communications: Practical Communication (10, 11, 12) 1 Semester, ½ Unit Fall or Spring

This introductory study of communication allows students to develop effective skills in practical communication situations. Emphasis is upon everyday, workplace communication skills such as personal communication, interviewing, listening, group discussions, and selected person-to-group communication. Students must complete assigned oral presentations to receive credit for this course. This course satisfies the oral communication graduation requirement.

120233 Oral Communications: Public Speaking (10, 11, 12) 1 Semester, ½ Unit Fall or Spring

The emphasis of this introductory study of oral communication is upon presentation in public settings. Students will be required to prepare and present in-depth, carefully research speeches. The course involves study of select communication theories. Focus includes nonverbal communication, language, planning and preparation of various types of public speeches, logical and emotional appeals, examination of classic, historical and student speech models. Students must complete assigned oral presentations to receive credit. This course satisfies the oral communication graduation requirement. This class is recommended for students who are planning to graduate with honors.



Please note the following:

Students wishing to enroll in any Debate or Forensics course must have instructor approval. Contact Mr. Hollis at 444-3050 or thollis@fayar.net at least one week prior to East Campus CAP conferences. All students desiring to enroll in any Debate or Forensics course must sign and follow a behavioral contract. Students disinterested or unable to participate in tournament competition should not enroll. Contact Mr. Hollis for a tentative tournament schedule.

120333 Argumentation and Debate (10, 11, 12) 1 Year, 1 Unit

This course is the study and practice of theories and strategies in argumentation and contest speech and debate. Students prepare and compete in speech and debate tournaments throughout the school year. Evaluation is based upon demonstrated effort, desire to improve, effective preparation and performance in practice and competition. Students must possess self-motivation, self-discipline, and a willingness to develop research skills. Students disinterested or unable to compete in tournaments should not enroll. Students will prepare and compete in Policy Team Debate, Lincoln-Douglas Debate, Controversy, Original Oratory, Extemporaneous Speaking, Student Congress, mock trial, and other competitive speaking events. Students must attend at least two tournaments per semester to receive credit. The debate/forensic tournaments function as the students' lab. Students enrolled in this class are expected to be exemplary representatives of Fayetteville High School, especially at tournaments and contests.

000010 Debate II (11, 12) 1 Year, 1 Unit

Prerequisites: Same as basic Debate/Forensics courses plus successful completion of Argumentation and Debate and membership in the National Forensic League.

This course is an extension of Argumentation and Debate, allowing 2nd year students to gain credit for continued study and participation in debate/forensics study and competition. Students will expand their studies and continue their competition in interscholastic debate/forensics tournaments for academic credit. Students will focus upon more advanced case formats and more effective presentational styles. Students must attend two tournaments per semester. Evaluation and behavioral components are similar to the basic debate/forensic classes.

000011 Debate III (12)**1 Year, 1 Unit****Prerequisites: Same as basis Debate/Forensics courses plus successful completion of Argumentation and Debate and a degree of excellence in the National Forensic League.**

This course allows students to gain academic credit for continued study and participation in Debate/Forensics competition. This course allows debate students to expand their studies to the championship level of interscholastic debate competition. Students must attend at least two tournaments per semester. Evaluation and behavioral components are similar to the basic debate/forensics courses.

120433 Forensics I (10, 11, 12)**1 Year, 1 Unit**

This course is the study and practice in preparation and presentation of interpretive and competitive speaking events such as interpretation of prose, poetry, drama, humor; storytelling, solo acting, duet acting, improvised duet acting, readers theater, mime, words and music, original oratory, and extemporaneous speaking. Students must prepare and compete in debate/forensics tournaments throughout the school year. Students must compete in at least two tournaments per semester to receive credit. The debate/forensics tournaments function as the students' lab.

000012 Forensics II (11, 12)**1 Year, 1 Unit****Prerequisites: Same as basis Debate/Forensics courses plus successful completion of Forensics and membership in the National Forensic League.**

This course allows 2nd year forensics students to gain academic credit for continued study and participation in debate/forensic competition. Second-year forensics students will expand their exploration and study of performance literature through continued competition in interscholastic debate/forensics tournaments. Students will be expected to focus and perform at more advanced levels in interpretive and speaking events offered in tournament competition. Students must attend at least two tournaments per semester. Evaluation and behavioral components are similar to the basic debate/forensics courses.

000013 Forensics III (12)**1 Year, 1 Unit****Prerequisites: Same as basis Debate/Forensics courses plus successful completion of Forensics II and attainment of the Degree of Honor in the National Forensic League.**

This course allows 3rd year forensics students to gain academic credit for continued study and tournament practice in debate/forensics competition. This course allows 3rd year forensics students to expand their exploration and study of performance literature through continued competition in interscholastic debate/forensics tournaments. Students will focus and perform at the most advanced levels in interpretive and speaking events offered in tournament competition. Students must compete in at least two tournaments per semester. Evaluation and behavioral components are similar to the basic debate/forensics courses.

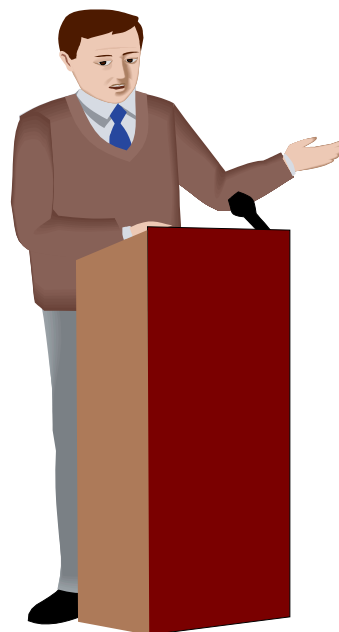

FHS Debate/Forensics students compete in 12-14 Debate/Forensics Tournaments in Arkansas and Missouri each school year. FHS is a member of the Carver-Truman National Forensic League District that consistently ranks annually as one of the top 25 NFL Districts out of 100+ districts nationally. FHS Debate/Forensics students win 1st, 2nd, and 3rd place in many of the various events at multiple tournaments each year. FHS continues to qualify over 10 students per year for National Forensic League membership.

PHYSICAL EDUCATION

510833 Weight Training (10, 11, 12) **1 Semester, ½ Unit** **Fall or Spring**

The heart of the course will be the weights program. Jogging, exercises, and sports activities will be included on off-days. Students will be evaluated based upon class participation, dressing out, and pre- and post-test skills.

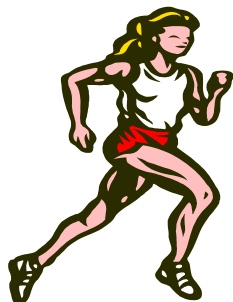

510933 Personal Fitness (10, 11, 12) **1 Semester, ½ Unit** **Fall or Spring**

This class will consist of exercise, cross country walking, and tae-bo. Students will be required to meet the state guidelines on learning life-long recreational skills. The participation fee for these activities will be the responsibility of the student. Students will be evaluated based upon class participation, dressing out, and pre- and post-test skills and semester test.



511033 Recreational Sports Activities (10, 11, 12) **1 Semester, ½ Unit** **Fall or Spring**

This class is designed to help students develop life-long recreational skills. Activities will be determined by student interest. The participation fee for these activities will be the responsibility of the student. The grade is earned by dressing out and participating and semester test.

511133 Team Sports A (10, 11, 12) **1 Semester, ½ Unit** **Fall or Spring**

This class will consist of games and activities utilizing the team concept. Student interest will determine many of the activities. Students will be required to meet the state guidelines on learning life-long recreational skills. The participation fee for these activities will be the responsibility of the student. Students will be evaluated based upon class participation, dressing out, and pre- and post-test skills and semester test.

Team Sports B/Athletics (10, 11, 12)

- 511333 Athletic Football**
- 511433 Men's Basketball**
- 511533 Women's Volleyball**
- 511633 Women's Basketball**
- 511733 Women's Soccer**
- 511734 Men's Soccer**
- 511833 Men's Baseball**
- 511933 Women's Softball**
- 531033 Cheer/Pom**

A credit for Athletics may be awarded at the rate of ¼ credit per semester up to 4 semesters or 1 credit.

Fall or Spring

Prerequisite: Instructor approval

This class will consist of team activities with emphasis on team play. The class will stress competition, health and fitness, conditioning, and teamwork on the competitive level. Contact Athletic Director Dick Johnson at Harmon Field House (973-8680) for more information.



SCIENCE

320133 Earth Science (10, 11, 12) **1 Year, 1 Unit**

This course is recommended for students who need a physical science credit. The class will focus on the methods of earth science; changes in the earth's crust through movement, weathering, and erosion; and the use of maps and other tools to chart the earth's landforms. The management of the earth's resources will also be investigated. The class will describe the geologic history of the earth from its formation to the present day form. A detailed study of oceanography and astronomy will accompany the study of the earth's atmosphere and the development of local weather patterns.

310103 Biology I (10) **1 Year, 1 Unit**

This course is a survey of major concepts in modern biology. The dominant theme of the course is relationships between living organisms and their environment. By the end of this course, students should be able to distinguish different plant and animal groups and will have gained an understanding of behavior, genetics, plant and animal reproduction and physiology. Students will conduct scientific investigations in the laboratory and on field trips to the Lake Fayetteville Environmental Study Center.

310203 Biology II (11, 12) **1 Year, 1 Unit**

Prerequisite: "C" or better average in Biology I

This course is designed for those students who want to continue their study of biology. Biology II will concentrate on the diversity of species and sustainability of life on Earth. The students will survey the six kingdoms of organisms. Identification of species with the school area will be conducted using various curricula material (G.L.O.B.E. and River's Curriculum). The fall semester will emphasize Kingdom Plantae, Kingdom Moneran, and Kingdom Protista. The fall semester will include a leaf collection plus other projects/labs related to the group being studied. The spring semester will include a study of Kingdom Fungi, Kingdom Animalia, and behavior of organisms. The students need to be prepared to write essays, lab reports, and one research paper. Biology II is responsible for the recycling at Bates Annex. The students must be willing to work, be a role model, and teach others about recycling. Good behavior and work ethics are a must for this class.

310302 Accelerated Biology (10) **1 Year, 1 Unit**

Prerequisite: "B" or better in Physical Science and Algebra I

Students and their parents will be expected to sign a class expectation contract before enrolling in the class. Students will read Rachel Carson's *Silent Spring* as a summer assignment.

This course is designed for students who have demonstrated exceptional science aptitude in their previous courses, and have an interest in biological science that might lead to a career. The course will follow an environmental approach similar to Biology I. The primary difference will be that each student in Accelerated Biology will be responsible for an independent study project which is a year-long activity conducted largely outside the classroom. This project will give students a chance to conduct a long-term science experiment similar to those carried out by working scientists. The student will choose an area of biology, study that area, and plan a project to answer a selected question. This is not just a research paper; there must be a hands-on component. The teacher will facilitate the process and require progress reports, but primary responsibility will be the student's.

310402 Field Biology (11, 12) **1 Year, 1 Unit**

Prerequisite: "C" or better average in Biology
Students requesting this course will be required to sign and follow a behavioral contract.

THIS IS AN ADVANCED COURSE. Major areas of study include map-reading, remote sensing, Arkansas Natural Divisions, geology, hydrology, soils, cave ecology, biomes, freshwater biology, biota of Arkansas, ecological relationships, and field trips. Students will participate in the Arkansas Water Education Team (WET). Students are expected to be intensely interested in field work. Expenses will be incurred for field trips during the year (for buses, entrance fees, camping fees, food, etc.) Students with poor attendance and/or failing grades will not be permitted to miss school for extended field trips. Contracts for behavior must be signed by the student and his/her parents/guardians before the student will be allowed to enroll in the class.

310521 AP Biology (11, 12)**1 Year, 1 Unit****Prerequisites:** Biology and Chemistry or Biology and concurrent enrollment in Chemistry

Students with a grade of “B” or better in the prerequisite courses are recommended for AP Biology. The course requires a good deal of laboratory work with a strong emphasis on molecular level biology and the biochemistry of living things.

310813 Human Anatomy/Physiology (11, 12)**1 Year, 1 Unit****Prerequisite:** “C” or better average in Biology**It is highly recommended that students take this course before or concurrently with chemistry rather than afterward.**

This is a college preparatory course using many labs and activities to get concepts across. This is a lab-oriented class designed to give those students considering careers in one of the medical health disciplines (kinesiology, zoology, genetics, biochemistry, nutrition, physical education/coaching) and the artist of the human form the background to be successful in their college courses. The first semester will concentrate on basic chemistry, biochemistry, and cytology. The second semester will concentrate on the anatomy and physiology of the major organ systems. Students will have the opportunity to develop skills in scientific inquiry, laboratory technique, analysis of data, and team cooperation. Concepts will be covered using as wide a variety of techniques as possible. Evaluation will be based upon participation, laboratory skills demonstrated, quizzes/tests, various activities, and field trips. Dissection of a fetal pig and observation of a cadaver are part of the curriculum.

320933 Chemistry (10, 11, 12)**1 Year, 1 Unit****Prerequisite:** “C” or better in Algebra I

Students in this course study the structure, composition, and properties of matter, and the chemical changes that matter undergoes. The course is rigorous and is designed to meet or exceed those standards required by the state and for college entrance. Students should expect outside study time to equal class time. It is recommended that only students with a grade of “C” or better for the first semester continue this course for the second semester.

321032 Accelerated Chemistry (10, 11, 12)**1 Year, 1 Unit****Prerequisite:** “B” or better in Algebra I

This course covers the structure and composition of matter and chemical changes. Material is covered at a substantially faster pace and in greater depth than in the standard course. This is a course for serious, self-motivated learners. It is recommended that only students with a grade of “C” or better for the first semester continue in this course for the second semester.

321111 AP Chemistry (11, 12)**1 Year, 1 Unit****Prerequisite:** Standard Chemistry with an “A” average or Accelerated Chemistry with a “B” or better **and** Algebra II with a “B” or better.

Advanced Placement Chemistry is equivalent to the first year of college chemistry. Students should expect outside preparation time of twice that of class time. The level of instruction is designed to prepare students to take the College Board AP Examination in chemistry.



321433 Physics A (10, 11, 12)

1 Year, 1 Unit

Prerequisite: “C” or better in both semesters of Algebra I and credit or enrollment in Algebra II. **(Recommended for the college-bound student or for those considering a technical career.)**

Physics is the most fundamental science and an important foundation course for many career paths, including engineering, computer science, architecture, and medicine. Physicists attempt to answer questions of great diversity: Why is the sky blue? What happens to an astronaut traveling at the speed of light? These topics will be covered (time permitting): motion, force, waves, gravitation, rotation, momentum, energy, special relativity, electricity, magnetism, light, optics, and sound. We will work for a conceptual understanding of physics along with a mathematical justification. This means you will have to think in this class. Physics students should have a solid background in algebra, as it will be used regularly. Work outside of the classroom, reading, problem solving, or doing independent research will be required. Significant class time will be spent in hands-on labs involving computer- and calculator-based lab equipment.

More information about this class is available at <http://fayar.net/east/teacher.web/science/reif/StanPhys.html>

321531 AP Physics B (10, 11, 12)

1 Year, 1 Unit

Prerequisite: “B” or better for both semesters of Algebra II, credit or enrollment in Trigonometry/Introductory Analysis, credit for Physics, or permission of the instructor

A college-level physics course incorporating algebra, trigonometry, and vectors. This course is designed for serious, self-motivated, successful science and math students seeking a challenge with the reward of possible college credit. Topics covered will include: motion, force, energy, momentum, circular motion, oscillations, gravitation, heat, fluids, thermodynamics, electricity, magnetism, waves (including sound), optics, modern physics, atomic physics, and nuclear physics. Prospective APPB students should note that the length of this list means the pace will be fast. Lab time during class will be shorter in this class due to time restrictions, but students will have the freedom to design their own labs in some cases. All students should expect to come to the AP exam review sessions outside of class time in the spring semester. A grade of “3” or better on the AP exam will result in credit for “College Physics” at many colleges and universities (up to 8 semester hours of credit). This credit will only count as an elective for students majoring in engineering or physical science at many universities; students planning scientific or technical careers should consider taking AP Physics C.

More information about this class is available at <http://fayar.net/east/teacher.web/science/reif/appb/APPB.html>

$$E=MC^2$$

321611 AP Physics C (11, 12)

1 Year, 1 Unit

Prerequisite: Credit in Trigonometry/Introductory Analysis, credit or enrollment in a calculus course, credit for a physics course, or permission of the instructor

This course is intended for students who truly enjoy math and science and are good at both. In other words, this is a course intended for students planning scientific or engineering careers. AP credit in this course is accepted for physical science and engineering majors at most universities. Motion, force, energy, momentum, oscillations, gravitation, electricity, and magnetism will be covered, but in greater depth and with more mathematical sophistication than our other physics courses. Calculus will be applied throughout the course. A grade of “4” or better on the AP Exam will result in credit for what is termed “University Physics” or “Physics for Engineering Students” at many universities (up to 10 semester hours of credit). At the end of the course, students may choose to take an APPC Mechanics test, an APPC Electricity and Magnetism test, or both. This course (as taught at FHS) usually concentrates on Mechanics, with the result that a high proportion of students earn a “qualified” score on the AP exam (3, 4, 5). It is possible that Electricity and Magnetism will be covered, as well. See the instructor for details. In APPC, student-designed labs will make up the majority of the labs. Students should be prepared to apply calculator- and computer-based technology to their lab analysis (no prior knowledge expected).

More information about this class is available at <http://fayar.net/east/teacher.web/science/reif/appc/APPc.html>

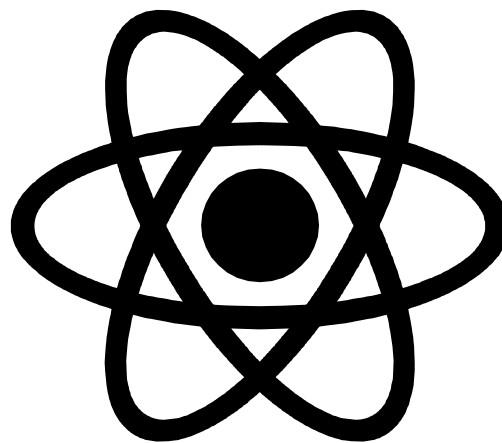

SOCIAL STUDIES

To graduate from Fayetteville High School a student must have the following social science credits:

| | |
|--|--|
| American History to Reconstruction - 1 Year | |
| American History 1877 to Present - 1 Year | 1) "Honors American Studies" 113102 2) "American Literature/AP U.S. History" 113003 3) "American History 1870 – Present" 430103 |
| World History - 1 Year | 1) "World History – Ancient/Medieval Civilization" 420713 2) "World History – Modern Civilization" 420913 3) "World History – AP European History 420511 |
| American Government - 1 Semester | 1) "American Government" 411513 2) "AP Government and Politics" 411311 |

430103 American History 1870-Present (10)
1 Year, 1 Unit

This course is a study of American history from post Civil War days to the present. The major areas of study include the Progressive Era, World War I, the Roaring Twenties, the Great Depression and the New Deal, World War II, the Cold War, Korea, Civil Rights, and Vietnam. Class activities may include map production, oral and written reports, posters, puzzles, lecture and note taking, film viewing, tapes, completing handouts, and discussing current events.

113102 Honors American Studies (10)
1 Year, 2 Units (1 unit of Sophomore English and 1 unit of AP U.S. History)
Prerequisite: A "B" or higher the first semester in both Pre-AP English and Pre-AP History

Honors American English and AP United States History are offered within a two-period time block for the sophomore who desires an extensive interdisciplinary approach to American literature and history and who has exhibited a high level of interest, dedication, and aptitude for previous language arts and social studies. These courses provide an in-depth study of American literature and history, identifying major historical time periods, literary figures, and their contributions. It is the intent of these classes to provide the student with both the historical and literary perspectives of nineteenth and twentieth century America and to provide an experience of writing across the curriculum. (See 430103 for other areas of study.) Completion of a summer assignment will be required for this course. Weighted credit is given only for the AP U.S. history portion of this course. Students will read and analyze: *The Jungle*, *All Quiet on the Western Front*, *The Grapes of Wrath*, *The Great Gatsby*, *A Separate Peace*, *The Crucible*, and a modern novel of their choice.

A nationally recognized critical thinking skills test will be used to identify students who have not taken Pre-AP English and History. To take this exam, please contact Ms. Caver or Ms. Sloan at 444-3050 or 442-5629.

113003 American Literature/American History (10)
1 Year, 2 Units (1 unit of American History and 1 unit of Sophomore English)

This two-semester course is designed for sophomores who will meet for a two-hour block to study American literature and history. Students will study the historical and literacy significance of events and analyze the voices of participants by conventional classroom methods of listening, speaking, presenting, note taking, questioning, and test performance skills. These activities will assure the student a position of active learning coupled with research based library projects and reading novels which instill an understanding of both literary and historical perspectives. Novel studies will include lessons from *Red Badge of Courage*, *The Jungle*, *All Quiet on the Western Front*, *The Great Gatsby*, *The Grapes of Wrath*, *The Sun Also Rises*, *A separate Peace*, and *Black Like Me*. Student projects will provide writing across the curriculum and the progression of learning according to Bloom’s Taxonomy which includes levels of knowledge, comprehension, application, analysis, synthesis, and evaluation.



450813 Geography (11, 12)
1 Semester, ½ Unit
Fall or Spring
Approval of Instructor

In Geography, the following themes are emphasized: 1) location: position on the earth’s surface; 2) place: physical and human characteristics; 3) relationships within places: humans and environments; 4) movement: humans interacting on the earth; and 5) regions: how they form and change.

461213 Sociology (11, 12)
1 Year, 1 Unit

Sociology is the scientific study of human interaction and relationships. This course is designed to address the major topics of general sociology. The first semester includes instruction in the scientific method and the applicability to society; the process of socialization, roles, structure of society, groups and social stratification. The second semester includes the study of problems of society: race and ethnic relations, an emphasis on the institutions and problems of each: family education, and religion. Instructional methods include lecture/discussion, current audio-visually, and research utilizing technology.

461113 General Psychology (11, 12)
1 Year, 1 Unit

Psychology is the scientific study of behavior. Through lecture, discussion, and topic-specific activities the major areas of psychology are addressed: theories of personality, biological basis of behavior, sensation and perception, learning and memory, abnormal behavior and treatment, motivation and emotion, research, and human development. Students have an opportunity to relate ideas from a psychological context to their own behavior. There are specific reading requirements beyond those in the text.

461411 AP Psychology (11, 12)
1 Year, 1 Unit

Advanced Placement Psychology provides the opportunity for students to participate in a learning experience similar to an entry-level college psychology course. This class is designed to follow the course outline recommended by the College Board and focuses on these major areas of study: theories of personality, biological basis of behavior, sensation and perception, learning and memory, abnormal behavior and treatment, motivation and emotion, research, human and treatment, motivation and demotion, research, human development, and social psychology. College credit may be earned with an acceptable score on the AP Psychology exam offered in May.

411513 American Government (11, 12)
1 Semester, ½ Unit
Fall or Spring

This course surveys the government and politics of the United States including an introduction to comparative systems and current events. Major topics include the Constitutional foundations of American government, federalism, the formal/informal institutions of government, civil rights and liberties, and public policy. Students will explore the concept of citizenship and the role they can play in their governmental system. This course receives government/civics credit based on national and state standards.

411311 AP Government and Politics (11, 12)
1 Year, 1 Unit

AP Government and Politics is a course designed to give students an analytical perspective on government and politics in the United States and to show how these issues impact upon public policy and the global community. One semester addresses American issues while the other semester covers the study of five other countries: The United Kingdom, France, The Russian Federation, China, and Mexico. After completing this course, students may take both the AP Examination in US Government and Comparative Politics (two separate tests). Class time will be spent in seminar-type discussions and note taking related to curriculum material augmented by daily current events. Other activities will include guest speakers, audiovisuals, Internet and library research, debates, and group and individual research projects. Outside reading will be required. This is recommended for students who are interested in learning how to be true “political animals”.

420713 World History Ancient/Medieval Civilization (11, 12)
1 Year, 1 Unit

This course of world history focuses on history from prehistoric times to the 1500's and concludes with an overview of the modern world and current events. Major topics include Mesopotamia, Egypt, India, China, Africa, the Americas, Greece, Rome, and the Middle Ages. A special emphasis also will be placed on the development and impact of religions, which includes Judaism, Buddhism, Hinduism, and Christianity as well as Islam. This course receives world history credit and is based on national and state standards.

420913 World History Modern Civilization (11, 12)
1 Year, 1 Unit

This course begins with an overview of world history to 1350. The focus of the class is from 1350 to the present and includes politics, society, culture, war, economics and geography. Topics include the Renaissance, the rise of nation-states, revolutions, imperialism, communism, world war, Sino-Japanese relations, apartheid, nationalism, and the Pacific Rim. This course receives world history credit and is based on state and national standards.



420511 World History AP European History (11, 12)
1 Year, 1 Unit

College credit is possible for this study of European history from approximately 1450 to the 1990's (the High Renaissance to the present). Students will need to spend approximately 45 minutes per night on class preparation. Among other goals, this course will present an analysis of the relationships in European political, social, economic, and intellectual history; an appreciation for the cultural contributions made by those who created our Western heritage; and an awareness of the consequence of European contacts with other areas of the world. Many colleges grant credit and/or exemption from Western Civilization or humanities requirements for satisfactory performance on the national AP European History exam. Although the focus of this class is modern European history, the first four weeks of the course and last two weeks provide an overview of world history. AP European History is based on College Board guidelines and national standards for world history. Students should come away with a thorough understanding of the foundations and institutions of the modern world. This course receives world history credit or humanities credit.

A nationally recognized critical thinking skills test will be used to identify students who have not taken the Pre-AP English and History. Students wishing to take this exam must contact Ms. Caver or Mr. Malony at 444-3050, ext. 100.



421623 Cultural Studies (12)
1 Year, 1 Unit

The course is designed to emphasize the interdependence and continuity of images, values, and ideas in American cultural history as documented by visual texts, i.e. film. The course is multidisciplinary and includes study units on law, science and technology, conformity and conflict, the public aspects of electronic media and its impact on policy and opinion, and various other themes. The seminar format is used, and students are responsible for readings and projects. Writing skills are stressed and essays are required. The course is for students interested in a holistic approach to the humanities within a nontraditional context. Although similar classes exist at the university level, the class is not restricted to college-bound students. All are encouraged to participate because the interaction of groups with diverse intellectual achievements and academic interests is vital to an integral educational experience.

460133 Street Law – A Course in Practical Law (12)
1 Semester, ½ Unit
Fall or Spring

Street Law will allow students to explore a wide range of legal principles necessary for understanding adult life in the United States, and to understand their practical application. Using a textbook, guest speakers, the Internet, class discussion and simulation activities, students will:

- explore practical elements of the criminal justice system
- know how criminal and civil trials are conducted
- learn what is necessary to make a binding contract
- understand how/why our justice system holds persons criminally or civilly liable for acts and omissions
- know their rights and responsibilities in leasing an apartment or buying a car
- understand the relationship between an employer and employee and how government has affected that relationship.

Please note:

The following two courses are “Step Ahead” (concurrent enrollment courses offered by Fayetteville High School and Northwest Arkansas Community College (NWACC). Students who wish to enroll pay tuition (approximately \$47 per credit hour) plus approximately \$50 for the text. Students must have an ACT score of 19 or higher on reading or a SAT verbal score of 470 or above. If the appropriate ACT and/or SAT scores are not available, students must score 41 or higher on the Compass. Students must have a 3.0 cumulative GPA or higher to take these courses. Compass is given at NWACC.

421710 Western Civilization I–WCIV 1003 (11, 12)
1 Semester, ½ Unit
Fall only

This course is a survey of Western development from the pre-historic period to 1650. Emphasis is on cultural, scientific, religious, and political contributions of the ancient, medieval, and early modern civilizations to 1650. This is a “Step Ahead” (concurrent) enrollment course offered by Fayetteville High School and Northwest Arkansas Community College (NWACC). This course receives 3 hours world history credit at the college level and receives one semester elective credit at the high school level.

421810 Western Civilization II-WCIV 1013 (11, 12)
1 Semester, ½ Unit
Spring only

The course is a survey of Western development from 1650 to the present. Emphasis is on the cultural, scientific, religious, and political development of modern Western civilization. In this semester course the student earns three college credit hours in world history and one semester elective credit at the high school level.

MISCELLANEOUS ELECTIVES

(ELECTIVE CREDIT ONLY)

000733 Student Council (10, 11, 12)

1 Year, 1 Unit

Prerequisite: Election

The projects carried out by Student Council members are concentrated in four areas: school spirit, teacher appreciation, fundraising, and community service. Projects have included bloodmobile drives, dances, homecoming and Colors Day activities, food drives, Habitat for Humanity, voter registration, spirit promotion, teacher appreciation activities, and school elections.

818255 Computer Repair-Diagnostics (10, 11, 12)

1 Year, 1 Unit

This course is an introduction to computer repair. Instruction includes basic and advanced hardware identification and configuration, troubleshooting techniques, troubleshooting tools, shop safety, and an introduction to Windows, Macintosh and Linux operating systems. This course is the first step towards A+ Computer Repair certification. Class is a full year ExplorNet program and is the pre-requisite for Computer Repair–Operating Systems and Computer Repair–Networking.

<http://www.explornet.com>

818245 Computer Repair-Computer Operations (11, 12)

1 Year, 1 Unit

Prerequisite: Computer-Diagnostics

An in depth look at all software related issues in computer repair and networking. Basic and advanced Operating System setup and configuration, including Windows and Linux. Custom setup and configuration study leads to advanced diagnostic and troubleshooting skills. This course also includes introduction to customer service and shop setup, customer satisfaction, digital photography, web page design and finishes preparation for the A+ Certification Exam. Class is a full year ExplorNet program and is a pre-requisite for Computer Repair-Networking.

<http://www.explornet.com>

818235 Computer Repair-Computer Networking (11, 12)

1 Year, 1 Unit

Prerequisite: Computer-Operating Systems

This course provides an introduction to computer networking setup, configuration, and maintenance. Network operating systems surveyed include Microsoft, Linux, and Novell. Course includes theory (OSI model) and hands-on labs featuring both actual network setups and the ExplorNet simulator. Class is a full year ExplorNet program and leads to NetPlus certification.

<http://www.explornet.com>

000833 Junior Air Force ROTC (10, 11, 12)

1 Year, 1 Unit

This course is designed to offer students a chance to experience Junior Air Force ROTC. Topics that will be covered include technology, drill, strategy, military procedures and protocol. Physical training, and some basic flight training. Uniforms and equipment will be furnished for the students. Students will be required to wear their uniform once a week.

921136 Transition (10, 11, 12)

1 Year, 1 Unit

This course is an introduction to the various aspects of career and job opportunities. Students will acquire knowledge about interests, aptitudes, and skills needed for occupational planning. Topics will include: resume writing, interviewing techniques, communication, test taking strategies, consumer mathematics, and vocational English. Each student will explore post secondary options to include vocational, community college, or university placement. The course is affiliated with existing apprenticeship programs of FHS.

818235 Computer Networking I (11, 12)

1 Year, 1 Unit

Prerequisite: Computer Repair

Through an innovative partnership with Cisco Networking Systems, this class offers students the opportunity to earn networking certification through the Cisco Academy Program. Computer Networking I is the first step towards the Cisco Networking Associate Certifications. The complete 4 semester course (Computer Networking I and Computer Networking II) cover the principles of designing, building and maintaining small to medium sized networks. The computer assisted instruction is complemented by hands on, project-driven training in high demand job skills. In this class, topics include the seven layer OSI reference model, data links and network addresses, data encapsulation, TCP/IP protocols, router elements, router configuration, IP addresses and troubleshooting techniques associated with all of the elements above.

818335 Computer Networking II (12)

1 Year, 1 Unit

Prerequisite: Computer Networking I

Computer Networking II is the final step towards the Cisco Networking Associate Certification. The complete 4 semester course (Computer Networking I and Computer Networking II) cover the principles of designing, building and maintaining small to medium sized networks. The computer assisted instruction is complemented by hands on, project-driven training in high demand job skills. In this class, topics include IPX addresses and encapsulation, Novell IPX, LAN segmentation, Fast Ethernet, WAN services, Frame Relay, ISDN networking, and troubleshooting techniques associated with all of the elements above. At the conclusion of his course the student will be prepared to take the Cisco Network Associates certification test.

NON-CREDIT CLASSES

000933 Study Hall

000943 Study Hall for Bus Riders

SPECIAL EDUCATION SERVICES

Programs provide assistance to any student who meets state and federal guidelines for these programs. Specialized instruction is provided to students with an identified disability and may also include related services. For further information contact the Office of Special Education at 444-3050 ext. 138.

NON-TRADITIONAL ACADEMIC SERVICES

Fayetteville High-East Campus offers two alternative programs for students, The Academy and School within a School (SwS). While each program is designed for non-traditional students, both are distinctly different in methods of instruction, curriculum, and the type of students served. Specific descriptions of the two programs follow this introduction.

Students in the Alternative Learning Environment (A.L.E.) Must take a minimum of two elective courses outside the A.L.E. Program. Students in both programs will take the four core courses within the program. The core classes will meet consecutively, which allows flexibility of time for projects, interaction with the University of Arkansas, guest speakers, etc. Various opportunities are provided for students in both programs to make up credit.

Enrollment in either the Academy or SwS is accomplished through an application process. Administrators, counselors, parents, self-referrals, and/or teachers may initiate this process. The A.L.E. committee (composed of an administrator, counselor, and teachers within the program) reviews the applications, the student's academic progress to the present time in school, and conferences with the student and parents/guardians. The appropriate placement will then be determined for the student into the A.L.E. program.

See page 46 for additional information regarding The Academy and School Within a School.

EAST CAMPUS SOPHOMORE ACADEMY

The Academy is a traditional/nontraditional program that emphasizes dynamic academic and relationship-building skills. It is an alternative learning environment that is dedicated to education and learning styles. It does NOT focus on containment, GED preparation and completion, or as an educational environment for “special needs” students that have behavioral problems.

This program is traditional in that it offers regular curriculum opportunities. As mandated by our district and state, The Academy teaches the Academic Standards, emphasizing “writing across the curriculum”. The traditional setting also allows for a variety of teaching techniques in order to reach all student learning abilities and, at the same time, provides structure for the students.

The Academy separates itself from the traditional school atmosphere in sharing students between four core teachers, stipulating smaller class sizes, and emphasizing integration of units. The block of classes provides time for implementing trust and social building skills (Social-Emotional Training classes) and mandatory parent conferences.

By virtue of the smaller class size and shared teachers, community and civic responsibility is stressed, transition from the junior high to the high school atmosphere is gentler, and supportive personal attention is afforded each student. The Academy welcomes 10th grade students who are looking for or needing a shared, caring academic community.

Automatic Admission to The Academy:

- 2 or less credits in core subjects for the 9th grade year
- 2.1 grade point average or below
- administrative mandated due to attendance, personal concerns, and/or socialization

Strongly Recommended to The Academy:

- habitual attendance difficulties
- chronic distraction by personal concerns
- petulant or reticent behavior in large groups, and/or individual settings

SCHOOL-WITHIN-A-SCHOOL (SwS) Sophomores, Juniors, and Seniors

SwS is an alternative program for intelligent, creative students who are NOT performing well in school and are at risk of dropping out of the conventional program. Characteristics of a SwS student typically include:

Capable of independent work and higher order thinking skills
Highly creative and individualistic, resists conformity
Feels depressed or exceedingly stressed
Easily disillusioned and frustrated
Seek group discussions and projects
Waning enthusiasm for or not caring about conventional school
High academic potential while underachieving

Approximately two-thirds of our students enter SwS as sophomores. Some remain until graduation. Others transfer into the conventional program as their confidence and enthusiasm for education increase. Still others enter SwS as juniors or seniors.

While functioning as an integral part of Fayetteville High, SwS is simultaneously a unique community. Students take four core courses with SwS. These meet each day during four consecutive periods, giving us flexibility for projects, interaction with the University, guest speakers, etc. In order for teachers to respond to individual interest and needs, it is essential that students be able to read and write well or take responsibility for developing approved alternative. The remaining two periods of the day are spent in regular classes offered outside of this program. Some SwS students are assisted in developing and carrying out individualized independent study courses either to make up credits or pursue unique areas of study.

WEST CAMPUS

2350 Old Farmington Road
Fayetteville, AR 72701
479-444-3058

West Campus is one of nineteen Secondary Area Vocational Centers located in Arkansas. It was the first center established in Arkansas and it is unique in that it is the only center that offers a complete academic curriculum as well as the technical offerings. Students from all over Northwest Arkansas can attend full or part time. All students who attend West Campus must be enrolled in at least one technical program of study. While some exploration of different technical areas is encouraged, in order to reap the maximum amount of benefit from attending West Campus students need to decide upon one area of technical concentration by their junior year and complete that program of study. All seniors must successfully complete a senior project before they graduate. The senior project is a product or project related to a student's technical area. The student completes the product, writes a research paper related to the product, and presents his or her work to a panel of judges. Honor Graduates receive a Certificate of Technical Mastery.

All technical courses are included as either core courses or electives in area specific programs of study provided by the Arkansas Department of Workforce Education. When a student follows the prescribed sequence of courses in a program of study they will reap the maximum amount of benefits to learning specific to that technical area. The district benefits by producing technical completers thereby assuring continued funding for the wide variety of Career and Technical programs offered by Fayetteville Schools and West Campus Technical Center.

Learn more about West Campus at www.fayar.net/west/index.html

WEST CAMPUS COURSE LIST

ACADEMIC LITERACY

Page 51

047633 Academic Literacy

AUTOMOTIVE COLLISION TECHNOLOGY

Page 51

837533 Auto Collision: Painting and Refinishing
837733 Auto Collision: Non-Structural Analysis and Repair
837633 Auto Collision: Structure Analysis and Repair
839833 Auto Collision: Apprenticeship

AVIATION MAINTENANCE TECHNOLOGY

Page 52

877530 General/Aviation I
877535 Airframe/Aviation II

BASIC SKILLS/PRE-GED CLASSES

Page 53

007533 Basic Skills/Pre-GED

BUSINESS TECHNOLOGY INFORMATION MANAGEMENT

Page 54

812333 Computerized Business Applications
810333 Word Processing I
810533 Desktop Publishing I
811213 Desktop Publishing II
817833 Spreadsheet Applications
810433 Word Processing II
492036 Multimedia Applications I
857533 Workplace Readiness
818433 Business Technology Apprenticeship

CHILD CARE AND GUIDANCE MANAGEMENT AND SERVICES

Page 55

827533 Child Care and Guidance Mgt. & Services
823033 Parenting
827733 Child Development
828033 Early Childhood Education Apprenticeship
823433 Family Dynamics
493008 Family and Consumer Science

COMMUNICATION AND FINE ARTS

Page 55

119633 Oral Communications
450001 Teen Art Explosion

COMPUTER SYSTEMS TECHNOLOGY

Page 56

818255 Computer Repair-Diagnostics
818245 Computer Repair-Computer Operations
818235 Computer Repair-Computer Networking
870133 Computer Systems Technology Apprenticeship

“CONCURRENT” STEP AHEAD

**NorthWest Arkansas
Community College**

Page 56

119730 English Composition I
119830 English Composition II
319530 Biology A

CONSTRUCTION TECHNOLOGY

Page 57

494048 Fundamentals of Construction
494046 Carpentry
494045 Bricklaying
494047 Concrete Masonry
494049 Drywall
494050 Electrical
494051 Plumbing
839933 Construction Technology Apprenticeship

COSMETOLOGY

Page 58

494055 Cosmetology I
494057 Cosmetology II

CRIMINAL JUSTICE

Page 58

858033 Law Enforcement: Fundamentals
858133 Law Enforcement: Patrol Procedures
858233 Law Enforcement: Criminal Law
858333 Law Enforcement: Criminal Investigation

DRAFTING**Page 59**

- 494070 Drafting & Design
- 494071 Architecture I/ Computer-Aided Drafting and Design
- 494074 Engineering I/Computer-Aided Drafting and Design
- 494073 Architecture II/ Computer-Aided Drafting and Design
- 494076 Engineering II/Computer-Aided Drafting and Design
- 837433 Drafting: Apprenticeship

ENGLISH**Page 60**

- 119093 English 9
- 118503 English 10
- 118013 English 11
- 117523 English 12
- 137533 Journalism I
- 137633 Journalism II
- 119730 College English Composition I
- 119830 College English Composition II

FASST: FAYETTEVILLE ADVANCED SPATIAL AND SERVICE TECHNOLOGY CENTER**Page 61**

- 001733 FASST I: Fayetteville Advanced Spatial and Service Technology Center
- 001833 FASST II: Fayetteville Advanced Spatial and Service Technology Center
- 001933 FASST III: Fayetteville Advanced Spatial and Service Technology Center

FOOD PRODUCTION MANAGEMENT AND SERVICE HOSPITALITY**Page 62**

- 493012 Food Production Management/Services
- 493004 Facilities Management/Services
- 493022 ProStart I
- 493023 ProStart II
- 493017 Lodging Management I
- 493018 Lodging Management II
- 828833 Food Production Management Apprenticeship

GEOGRAPHIC INFORMATION SYSTEMS**Page 64**

- 494090 Introduction to GIS
- 494091 GIS and Remote Sensing
- 494092 SPACE
- 494093 STARS

GRAPHIC COMMUNICATION/PRINTING**Page 64**

- 494096 Fundamentals of Graphic Communication/Beginning Level Printing
- 494099 Offset Press Operation
- 494095 Electronic Imaging

HEALTH AND P.E.**Page 65**

- 517533 Physical Education
- 528033 Health Education

HORTICULTURE**Page 65**

- 491028 Introduction to Horticulture Science
- 847633 Horticulture: Plant and Soil Science
- 847733 Horticulture: Green House Management
- 848233 Horticulture: Small Gas Engines
- 848833 Turf Grass Management
- 848733 Horticulture: Landscape Design, Installation and Management
- 491011 Agriculture Science
- 491030 Managing Our Natural Resources
- 848933 Horticulture Apprenticeship

INDEPENDENT/GUIDED STUDY**Page 66**

- 001133 Independent Study

MATHEMATICS**Page 66**

- 238733 Algebra I
- 238933 Algebraic Connections
- 237533 Algebra II
- 248033 Geometry

MEDICAL PROFESSIONS**Page 67**

- 494129 Introduction to Medical Professions-Part 1
- 494131 Introduction to Medical Professions-Part 2
- 494128 Medical Procedures
- 494132 Medical Terminology
- 868035 Medical Professions: Dental Assisting I
- 868033 Medical Professions: Dental Assisting II
- 494125 Human Anatomy & Physiology
- 494126 Medical Professions: Career Specialization
- 867533 Medical Professions Apprenticeship

PRE-ENGINEERING**Page 68**

837033 Introduction to Engineering Design
837035 Principles of Engineering
837133 Digital Electronics
837233 Computer Integrated Manufacturing
837055 Engineering Design and Development
877833 Engineering Apprenticeship

SCIENCE**Page 69**

320133 Earth Science
318533 Biology
319530 College Biology A/Principles of Biology
327533 Physics
328033 Chemistry
329033 Physical Science

SOCIAL STUDIES**Page 70**

419533 American Government
429033 World History
437633 U.S. History I
437733 U.S. History II

SPECIAL EDUCATION SERVICES**Page 70****WELDING****Page 70**

494157 Metal Fabrication
494155 Gas Metal Arc Welding
494158 Shielded Metal Arc Welding
494156 Gas Tungsten Arc Welding
839133 Welding Apprenticeship

WEST CAMPUS COURSE DESCRIPTIONS

ACADEMIC LITERACY

047633 Academic Literacy (9, 10, 11, 12) **18 Weeks, 1 Unit**

All students entering West Campus will be required to demonstrate a level of proficiency in reading or schedule this class for elective credit to achieve competency. Students will take a placement test to determine assignment to this class.

The students will be exposed to non-traditional methods and strategies in order to reach a level of development consistent with further studies at West Campus. The class will be scheduled during a single block period with consideration given to students' needs specific to their learning styles and time on task requirements.

AUTOMOTIVE COLLISION TECHNOLOGY

Automotive Collision (10, 11, 12) **18 Weeks, 1 Unit**

- 837533 Auto Collision: Painting and Refinishing**
- 837733 Auto Collision: Non-Structural Analysis and Repair**
- 837633 Auto Collision: Structure Analysis and Repair**

This course of study is designed to provide the graduate with entry level knowledge and skills in auto body construction, properties of metals, estimating, straightening bodies and frames, filling, sanding, welding, painting, and the removal and replacement of body trim. Students have ample opportunity to develop skills through hands-on practice, as well as learn to use the various hand power tools. Safety skills will also be emphasized.

839833 Auto Collision: Apprenticeship (11, 12)

The Automotive Collision Technology Apprenticeship is designed to prepare high school juniors and seniors for careers in automotive collision technology. Students will have an opportunity to interview for jobs at appropriate work sites where they will work part of each day. Students can earn ½ credit (180 hours per semester or 10 hours per week), or 1 credit (270 hours per semester or 15 hours per week), or 1½ credits (360 hours per semester or 20 hours per week). Students enrolled in apprenticeships must also enroll in related classes recommended by their apprenticeship teacher. **Some employers require drug testing as a condition for employment.**



AVIATION MAINTENANCE TECHNOLOGY

www.arkansasaviation.org

The Federal Aviation Administration (FAA) approved Aviation Maintenance Technician Program is comprised of three main sections: General, Airframe, and Powerplant. Through West Campus Technical Center, students may attend classes at Arkansas Aviation Tech Center in Fayetteville. **Students start with the General section during their junior or senior year and then take various Airframe courses.**

877530 General/Aviation I (11, 12) 36 Weeks, 4 Units

General Aviation/Basic Subjects - 461 Hours

Introduction to Aviation
Mathematics
Basic Physics
Aircraft Drawings
Aircraft Weight and Balance
Fluid Lines and Fittings
Basic Electricity
Aircraft Cleaning & Corrosion Control
Materials & Processes
Ground Operations & Handling
Maintenance Forms and Records
Introduction to Computer Technology

The following sections (Airframe & Powerplant) may be completed after graduation. Credit will be given for all Airframe subjects taken during high school. The value of this credit is up to \$4,400 for students that complete both years.

Successful completion of the Airframe and/or Powerplant Sections will qualify the student to take the Federal Exams. Federal Exams include a computerized test for each section. Additionally, there is an Oral and Practical Examination administered for each Section by an FAA Designated Mechanic Examiner which requires students to answer oral questions and perform actual aircraft maintenance. Minimum score on all tests is 70%. Department of Transportation may require drug testing for all persons certifying airworthiness of aircraft. Students must be 18 years of age **at the time of certification.**

877535 Airframe/Aviation II (12) (Certification Course) 36 Weeks, 4 Units

Students will complete 417 of 757 hours in the high school program.

Airframe and Structure Subject - 757 Hours

Introduction to Airframe Structures
Welding
Assembly and Rigging
Wood Structures/Coverings/Finishes
Sheet Metal & Non-metallic Structures
Airframe Electrical
Ice & Rain Control/Fire Detection & Warning
Communications & Navigation (Avionics)
Cabin Atmosphere
Hydraulics & Pneumatics
Landing Gear
Fuel Systems
Aircraft Inspection & Review

Powerplant Section (After high school)

Engine/Related Systems Subjects - 742 Hours

Introduction to Powerplant
Propellers
Engine Lubrication & Cooling
Induction/Airflow/Exhaust & Thrust Reversers
Engine Instruments
Engine Fire Protection
Engine Fuel Control & Fuel Metering
Ignition & Starting
Engine Electrical/Auxiliary Power Units
Reciprocating Engines
Turbine Engines/Un-ducted Fans
Engine Inspection and Review

The FAA Airframe and Powerplant Certificate is required by Federal Law for all persons performing maintenance on any U.S. Registered Aircraft. The certificate is globally recognized as the standard for quality of aircraft maintenance. This demanding program will prepare students to enter an elite workforce that helps ensure the safety of the flying public. Aviation Maintenance Technician classes are held at the Fayetteville Municipal Airport.

The U.S. Department of Labor projects a need for at least 12,000 new airframe and powerplant technicians a year and foresees a shortfall of 155,000 technicians by 2006.

BASIC SKILLS/PRE-GED CLASSES

007533 Basic Skills/Pre-GED

Students who are 16 or 17 years old may enroll in pre-GED classes if they meet the state grade equivalency guidelines. This is a non-credit course designed for students

who are deficient in credits toward graduation. Parental permission is required by the state. When students are ready for the actual GED test they will be released to the Adult Education Center where the test is administered.

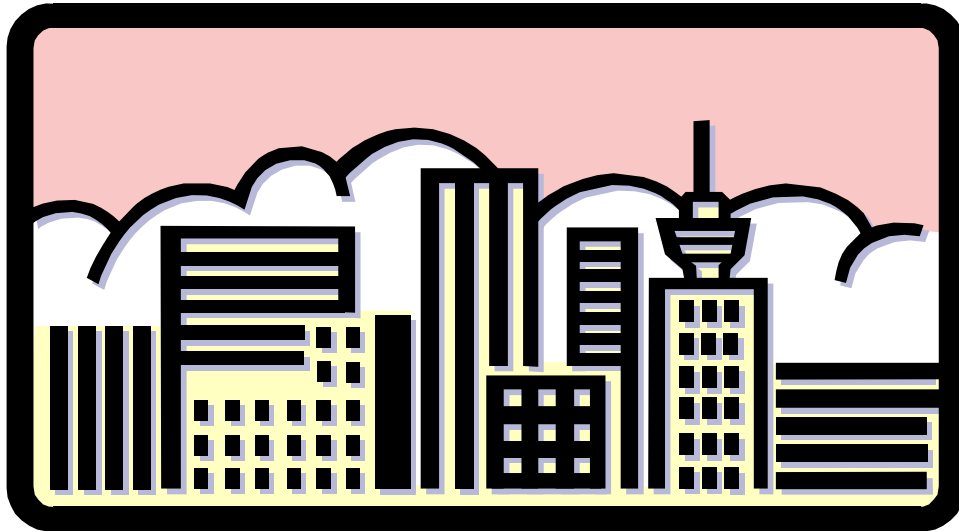

The Fayetteville Youth Apprenticeship program serves 93 students from east and west campuses.

Currently working with the Fayetteville Youth Apprenticeship are 191 business/industry partners, 17 secondary education partners, 6 post-secondary education partners, and 21 government/community partners.

The Youth Apprenticeship Education Partnerships are with: Northwest Arkansas Community College (Rogers), Northwest Technical Institute (Springdale), North Arkansas College (Harrison), the University of Arkansas (Fayetteville), Westark (Ft. Smith), and Arkansas Valley Technical Institute (Ozark).

Since 1992, the Youth Apprenticeship Program has had 46 completers of the four-year training program.

Presentations on the Fayetteville Youth Apprenticeship program have been given at three national education conferences.

Fayetteville Youth Apprenticeship teachers developed a training workshop for teachers and administrators from over 100 participating schools with grant funding recently received.

Fayetteville Youth Apprenticeship students were selected to present a workshop in July of 2001 at the National Integration Conference in Beaver Creek, Colorado.

BUSINESS TECHNOLOGY INFORMATION MANAGEMENT

812333 Computerized Business Applications (10, 11, 12)
18 Weeks, 1 Unit
Prerequisite: Keyboarding or typing

Computerized Business Applications is an 18-week course designed to prepare students with an introduction to business applications. Emphasis is given to hardware, concepts, and business uses of applications. The business applications covered are spreadsheets, word processing, database, graphics, integrated software, electronic mail, management-support software, and image processing.

810333 Word Processing I (10, 11, 12)
9 Weeks, ½ Unit
Prerequisite: Computerized Keyboarding

This course is designed to provide students with fundamental word processing skills necessary to produce simple documents. Topics include creating and editing documents, proofreading, text alignments and enhancements, formatting documents, and multiple-page documents. Microsoft Word will be used for this course.

810533 Desktop Publishing I (10, 11, 12)
9 Weeks, ½ Unit

Desktop Publishing I is a one-semester course that will teach students to combine the versatility of the computer with page design software enabling students to produce materials of near photo-typeset quality. The course includes page composition, layout, design, editing functions, and a variety of printing options.

811213 Desktop Publishing II (10, 11, 12)
9 Weeks, ½ Unit
Prerequisite: Desktop Publishing I

Desktop Publishing II is a semester course designed to study the process of analyzing information and choosing the appropriate visual signals to communicate the desired message effectively. Applied principles are used to analyze and organize information, set up a design structure, and produce special visual expressions.

817833 Spreadsheet Applications (10, 11, 12)
9 Weeks, ½ Unit
Prerequisite: Computer Tech Intro or Word Processing

This course will explore various software packages that are used in business today. This course is similar to the introductory computer course of most colleges. This course will use a popular spreadsheet program used in business today, MS Excel, and will be devoted to exploring the database management program of Microsoft Access.

810433 Word Processing II (10, 11, 12)
9 Weeks, ½ Unit
Prerequisite: Keyboarding and Word Processing I

Word Processing II is a 9 week course designed to provide students with entry-level skills in word processing concepts, operations, text manipulations, and production of business documents using a computer. MS Word 2000 will be used.

492036 Multimedia Applications I (10, 11, 12)
9 Weeks, ½ Unit
Prerequisite: Word Processing I

Multimedia Applications I is a one-semester course giving students experience in using multimedia to merge text, graphics, video and sound. Applied principles are used to analyze and organize information, set up a design structure and produce special visual expressions.

857533 Workplace Readiness (10, 11, 12)
9 Weeks, ½ Unit

Workplace readiness is a 9 week class. This class is designed for all vocational students to prepare them for entering the workforce. The student will learn teamwork, problem solving, and self management skills. The student is also profiled for career choices.

818433 Business Technology: Apprenticeship (11, 12)

The Business Apprenticeship program is designed to prepare high school juniors and seniors for careers in computer related fields. Students will have an opportunity to interview for jobs at appropriate work sites where they will work part of each day. Students can earn ½ credit (180 hours per semester or 10 hours per week), or 1 credit (270 hours per semester or 15 hours per week), or 1½ credits (360 hours per semester or 20 hours per week). Students enrolled in apprenticeship must also enroll in related classes recommended by their apprenticeship teacher. **Some employers require drug testing as a condition for employment.**



CHILD CARE AND GUIDANCE MANAGEMENT AND SERVICES

<http://fayar.net/west/dept/childcare/index.htm>

827533 Child Care and Guidance Mgt. & Services (10, 11, 12) 18 Weeks, 1 Unit

This class provides information on employability skills, planning a child care facility, guiding children's behavior, and caring for children with special needs. Students will also be involved in a pre-employment laboratory experience with the licensed infant/toddler center. Students will receive state certification as a child care assistant, child care aide, or as a child care teacher.

823033 Parenting (10, 11, 12) 9 Weeks, ½ Unit

This class is designed to provide pregnant and parenting students as well as other students interested in early childhood careers with the opportunity to develop the skills needed for successfully working with young children. This class deals with pregnancy/the early parenting years. Child guidance techniques are refined as students work with infants and toddlers in the licensed child care center.

827733 Child Development (10, 11, 12) 9 Weeks, ½ Unit

This class teaches the principles of child development, including basic child care techniques such as childbirth education, holding, lifting, feeding and diapering. This class is designed for parenting students as well as other students interested in early child care careers.

For over ten years, the West Campus Child Care/Parenting Center has offered child care services and parenting classes to low income teen parents.

The West Campus Childcare Center is open to the public and serves children from six weeks to three years. The Center has a full-time nurse funded by the United Way.

828033 Early Childhood Education Apprenticeship (11, 12) 18 Weeks, 1 Unit

Prerequisite: Approval of instructor

Students interested in Early Childhood Careers are eligible to participate in the Youth Apprenticeship program. Jobs and skill training are designed specifically to prepare students for future employment. Students can earn ½ credit (180 hours per semester or 10 hours per week), or 1 credit (270 hours per semester or 15 hours per week), or 1½ credits (360 hours per semester or 20 hours per week). Students enrolled in apprenticeships must also enroll in related classes recommended by their apprenticeship teacher. **Some employers require drug testing as a condition for employment.** Contact Dr. Beth A. Higgs at 444-3058, ext. 147, for additional information.

823433 Family Dynamics (10, 11, 12) 18 Weeks, 1 Unit

This course is designed to connect student learning to real life situations. Topics that will be covered include life relations, crisis management, civic responsibility, and career planning.

493008 Family and Consumer Sciences (10, 11, 12) 18 Weeks, 1 Unit

Family and Consumer Science is designed to provide students with basic information and skills needed to function effectively within the family and within a changing, complex society. Upon completion of this course, the student should have developed basic life skills that promote a positive influence on the quality of life.

COMMUNICATION AND FINE ARTS

119633 Oral Communications (11, 12) 9 Weeks, ½ Unit

This class is an introduction to the study of oral communication skills through classroom presentation of speeches, discussions, and nonverbal activities. Outstanding students may be encouraged to compete in speech contests.

450001 Teen Art Explosion 9 Weeks, ½ Unit

Teen Art Explosion is designed to assist students with personal needs by involving them in creative art experiences and youth counseling. Students will be exposed

to a variety of art media such as drawing, painting, sculpting, ceramics, paper and fiber arts, photography, videography, the dramatic arts and music to engage their creativity. In addition to learning to recognize and use the elements and principles of art, students will learn to draw upon life experience to create meaningful works of art. Student opinions will be asked for and valued.

Attitudes toward responsibility, self worth, substance abuse, prejudice, relationships with peers as well as the community at large will be explored. Students will also be encouraged to apply for a position with the Teen Art Explosion summer program upon completion of this course.

COMPUTER SYSTEMS TECHNOLOGY

<http://fayar.net/west/flite/index.html>

818255 Computer Repair-Diagnostics (10, 11, 12) **18 Weeks, 1 Unit**

This course is an introduction to computer repair. Instruction includes basic and advanced hardware identification and configuration, troubleshooting techniques, troubleshooting tools, shop safety, and an introduction to Windows, Macintosh and Linux operating systems. This course is the first step towards A+ Computer Repair certification. Class is a full year ExplorNet program and is the pre-requisite for Computer Repair–Operating Systems and Computer Repair–Networking.
<http://www.explornet.com>

818245 Computer Repair-Computer Operations **(11, 12)** **18 Weeks, 1 Unit**

An in depth look at all software related issues in computer repair and networking. Basic and advanced Operating System setup and configuration, including Windows and Linux. Custom setup and configuration study leads to advanced diagnostic and troubleshooting skills. This course also includes introduction to customer service and shop setup, customer satisfaction, digital photography, web page design and finishes preparation for the A+ Certification Exam. Class is a full year ExplorNet program and is a pre-requisite for Computer Repair-Networking.
<http://www.explornet.com>

818235 Computer Repair-Computer Networking **(11, 12)** **18 Weeks, 1 Unit**

This course provides an introduction to computer networking setup, configuration, and maintenance. Network operating systems surveyed include Microsoft, Linux, and Novell. Course includes theory (OSI model) and hands-on labs featuring both actual network setups and the ExplorNet simulator. Class is a full year ExplorNet program and leads to NetPlus certification.
<http://www.explornet.com>

870133 Computer Systems Technology Apprenticeship **(11, 12)**

Computer Systems Technology Apprenticeship program is designed to prepare high school juniors and seniors for careers in computer repair and networking. Students accepted for the Computer Systems Technology Apprenticeship will have an opportunity to interview for jobs at appropriate work sites where they will work part of each day. Students can earn ½ credit (180 hours per semester or 10 hours per week), or 1 credit (270 hours per semester or 15 hours per week), or 1½ credits (360 hours per semester or 20 hours per week). Students enrolled in apprenticeships must also enroll in related classes recommended by their apprenticeship teacher. **Some employers require drug testing as a condition for employment.**

“CONCURRENT” STEP AHEAD

NorthWest Arkansas Community College (11, 12)

Fayetteville Juniors and Seniors may enroll in courses at NWACC. All students must take the ASSET test to be recommended for NWACC courses. Juniors and Seniors may take courses as part of their high school schedule within these guidelines:

- Each 3-hour credit course at NWACC equals ½ credit.
- Students must provide their own transportation and are responsible for all class tuition and fees.
- Students may choose to have dual credit for their courses. The NWACC course can be counted as part of the FHS transcript and grade point average.
- Eligibility for sports and activities will be based on community college and high school classes.
- All students will be required to complete the NWACC credit form obtained from the West Campus counseling office.

Courses offered are:

119730 English Composition I

119830 English Composition II

319530 Biology A

119730/ENGL 1013 English Composition I

This course emphasizes the process of writing clear, concise, developed expository prose through practice and class discussion of writing. Preparation of regularly scheduled papers, including a research assignment, is required.

119830/ENGL 1023 English Composition II

Prerequisite: 119830/ENGL 1013

This class offers an introduction to the critical interpretation of literature. Through lectures, class discussions, library research and writing assignments, students acquire an ability to analyze literary works.

319530/BIOL1544 Biology A/ Principles of Biology I

This course is an introductory college course in biology that surveys various levels of organization from atoms to biomes. Topics of study include problem-solving by means of the scientific method, the chemistry of life, cellular and sub-cellular biology, metabolism, cell reproduction, genetics, animal organization and survey, and basic ecological and evolutionary principles.

CONSTRUCTION TECHNOLOGY

Construction Technology is a sequential course of study designed to prepare the student for immediate entry into the workforce or post-secondary education. The Advanced Trades courses are taught each nine weeks concurrently with the Fundamentals and Carpentry courses.

Basic Courses

494048 Fundamentals of Construction (10, 11, 12) **18 Weeks, 1 Unit**

An instructional program that prepare individuals to apply technical knowledge and skills in the building, inspecting, and maintaining of structures and related properties.

494046 Carpentry (10, 11, 12) **18 Weeks, 1 Unit**

Prerequisite: Fundamentals of Construction

An instructional program that prepares individuals to apply technical knowledge and skills to layout, fabricate, erect, install, and repair wooden structures and fixtures, using hand and power tools.

Two West Campus students placed second and third place in Job Skills Demonstration at the State SkillsUSA VICA competition.

Advanced Trades

These courses emphasize the skills and knowledge needed to enter the trade of choice.

494045 Bricklaying (10, 11, 12) **18 Weeks, 1 Unit**

Prerequisite: Fundamentals of Construction and Carpentry

An instructional program that prepares individuals to apply technical knowledge and skills in the laying and/or setting of brick, concrete, block, hard tile, marble and related materials, using trowels, levels, hammers, chisels, and other hand tools.

The West Campus Construction Technology program is certified by the National Association of General Contractors.

494047 Concrete Masonry (10, 11, 12) **18 Weeks, 1 Unit**

Prerequisite: Fundamentals of Construction and Carpentry

An instructional program that prepares individuals to apply technical and skills in placing and finishing concrete.

494049 Drywall (10, 11, 12) **18 Weeks, 1 Unit**

Prerequisite: Fundamentals of Construction and Carpentry

An instructional program that prepares individuals to apply technical knowledge and skills in installing and finishing drywall.

494050 Electrical (10, 11, 12) **18 Weeks, 1 Unit**

Prerequisite: Fundamentals of Construction and Carpentry

An instructional program that prepares individuals to apply technical knowledge and skills to install and repair residential systems.

494051 Plumbing (10, 11, 12) **18 Weeks, 1 Unit**

Prerequisite: Fundamentals of Construction and Carpentry

An instructional program that prepares individuals to apply technical knowledge and skills to lay out, assemble, install, and maintain piping fixtures and piping systems, hot water, heating, cooling, and drainage systems.

839933 Construction Technology **Apprenticeship (11, 12)**

The Construction Technology Apprenticeship program is designed to prepare high school juniors and seniors for careers in building trades. Students will have an opportunity to interview for jobs at appropriate work sites where they will work part of each day. Students can earn ½ credit (180 hours per semester or 10 hours per week), or 1 credit (270 hours per semester or 15 hours per week), or 1½ credits (360 hours per semester or 20 hours per week). Students enrolled in apprenticeships must also enroll in related classes recommended by their apprenticeship teacher. **Some employers require drug testing as a condition for employment.**

COSMETOLOGY

494055 Cosmetology I (11)

18 Weeks, 1 Unit

Prerequisite: Completion of 10th grade

Cost to Student: \$10.00 State Board Permit
\$397.13 Beauty Kit (payment plans available)

494057 Cosmetology II (12)

18 Weeks, 1 Unit

Prerequisite: Successful completion of Cosmetology I

These classes are located at the Fayetteville Beauty College in the Westwood Plaza on West 6th Street. The goal is to provide an up-to-date course of instruction that will equip and prepare students for a successful career in the beauty industry. Students will be provided

the proper training needed to realize their full potential as a professional cosmetologist. This is a 1500 clock hour program that meets Tuesdays - Saturdays, mornings or afternoons. It will take both the Junior and Senior year to complete. The course consists of all phases of basic cosmetology: shampooing; hair cutting; hair styling, perming, color techniques; manicures; and facials. Upon completion of the 1500 hours, students are eligible for state licensing exams. Students enrolling in this program will need to call the Fayetteville Beauty School (501-521-3571) to schedule a meeting with the Director one month before classes begin.

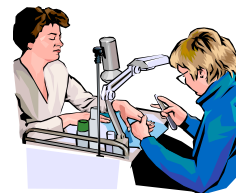

CRIMINAL JUSTICE

http://fayar.net/west/dept/criminal%20justice/criminal_justice.htm

These courses prepare individuals to perform the duties of police and public security officers, including patrol and investigative activities, traffic control, crowd control and public relations, witness interviewing, evidence collection and management, basic crime prevention methods, weapon and equipment operation and maintenance, report preparation, and other routine law enforcement responsibilities.

858033 Law Enforcement: Fundamentals (10, 11, 12)

18 Weeks, 1 Unit

The teaching units included are: the criminal justice system, criminal justice professions, communicating with others, interpreting criminal and civil laws, legal use of force, and the SkillsUSA VICA student organization.



858133 Law Enforcement: Patrol Procedures (11, 12)

18 Weeks, 1 Unit

The teaching units include: responding to emergencies, controlling traffic, performing patrol functions and the SkillsUSA VICA student organization.

858233 Law Enforcement: Criminal Law (11, 12)

18 Weeks, 1 Unit

The teaching units include: custody procedures, the court system, the juvenile justice system, preventing crime, and the Skills USA VICA student organization.

858333 Law Enforcement: Criminal Investigations (11, 12)

18 Weeks, 1 Unit

The teaching units included: narcotics and dangerous drug laws, investigating crimes, search and seizure, evidence, arresting suspects, and the SkillsUSA VICA student organization.

DRAFTING

494070 Drafting & Design (10, 11, 12) 18 Weeks, 1 Unit

This course provides beginning level instruction in drafting and design, architectural drawing, engineering drawing, and computer-aided drafting. The student will explore these areas as possible career choices. This course includes the essential drafting skills necessary for those entering post-secondary technical institutes, junior colleges, and universities to study Drafting and Design, Architecture, and Engineering.

494071 Architecture I/Computer-Aided Drafting and Design (10, 11, 12)

Prerequisite: Drafting & Design

494074 Engineering I/Computer-Aided Drafting and Design (10, 11,12)

Prerequisite: Drafting & Design

18 Weeks, 1 Unit

These courses provide the student an opportunity to specialize in the field of architectural or engineering drafting and design. The student will refine his/her drafting skills by completing mostly computer-aided drafting problems with some manual drafting. Engineering students will solve problems related to civil and mechanical engineering. Architectural students will study and complete projects involving residential and commercial design and construction.

In ten out of the last twelve years, West Campus drafting and design students have placed first in the state in competition with other schools in Arkansas. In the year we didn't win first, we placed second.

A West Campus drafting and design student designed the Vietnam Veterans Memorial located on the State Capitol grounds in Little Rock.

494073 Architecture II/Computer-Aided Drafting and Design (11, 12)

Prerequisite: Architecture I/Computer-Aided Drafting and Design

494076 Engineering II/Computer-Aided Drafting and Design (11,12)

Prerequisite: Engineering I/Computer-Aided Drafting and Design

18 Weeks, 1 Unit

These courses provides the advanced student an opportunity an opportunity to further develop and specialize in the field of either architectural design and drafting, or engineering drafting and design. The student will refine his/her drafting skills by completing computer-aided drafting problems. Engineering students will study and complete projects involving residential and commercial design and construction. Career choices and opportunities will be explored. Job-entry level skills for some drafting positions should be achieved by students.

837433 Drafting Apprenticeship (11, 12)

The Drafting Apprenticeship program is designed to prepare high school juniors and seniors for careers in drafting. Students accepted for the Drafting Apprenticeship will have an opportunity to interview for jobs at appropriate work sites where they will work part of each day. Students can earn ½ credit (180 hours per semester or 10 hours per week), or 1 credit (270 hours per semester or 15 hours per week), or 1½ credits (360 hours per semester or 20 hours per week). Students enrolled in apprenticeships must also enroll in related classes recommended by their apprenticeship teacher. **Some employers require drug testing as a condition for employment.**

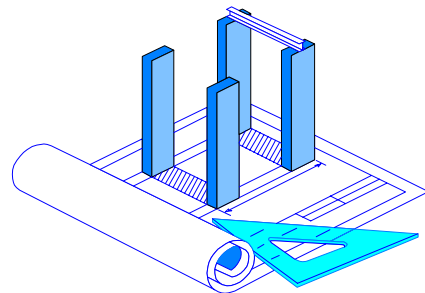

ENGLISH

<http://fayar.net/west/dept/English/ccollier/index.html>

119093 English 9 **18 Weeks, 1 Unit**

This course teaches listening, speaking, and writing skills through practice. The grammar part of this class will consist of the parts of speech, usage, and sentence structure. The literature part of the course will consist of drama, poetry, short stories, and novels.

118503 English 10 **18 Weeks, 1 Unit**

This course teaches, through practice and application, the skills of reading, writing, speaking, and listening. An emphasis is placed on sentence structure, usage, and grammar. The literature part of this class will teach short stories, drama, poetry, and novels.

118013 English 11 **18 Weeks, 1 Unit**

This course teaches, through practice and application, the skills of reading, writing, speaking, and listening. These skills will be applied to practical situations in the working world. Each student is required to study American literature, grammar, usage, composition, reading, and writing. Students will also be exposed to activities to prepare them for senior projects.

117523 English 12 **18 Weeks, 1 Unit**

Prerequisite: Successful completion of English 9, 10, and 11. It is also recommended that students take English 12 during the semester they will be graduating.

This course emphasizes the application of reading, writing, listening, and speaking skills. A major part of this course will be integrating academic and technical skills by preparing the Senior Project. Students will select a research topic related to their technical area, write a research paper, develop a product, and make an oral presentation. Students will also read and research classical as well as modern literature. Students successfully completing English 12 will have the skills necessary for personal, work, and post secondary situations. This class specifically addresses business' demands that future employees have good communication and research skills. The literature part of this class will teach short stories, drama, poetry, and novels.

137533 Journalism I (10, 11, 12) **18 Weeks, 1 Unit**

This class is an elective credit based on the application of media skills to the production of the campus newsletter and yearbook as well as other media during the course of the school year. These media skills include writing copy of print/broadcast, layout design, and photography.

137633 Journalism II (11, 12) **18 Weeks, 1 Unit**

This course extends the students' layout/design skills and includes digital photography and web publishing.

NorthWest Arkansas Community College (11, 12)

Fayetteville Juniors and Seniors may enroll in the following English courses at NWACC. See "Concurrent" Step-Ahead (page 56) for more information.

119730/ENGL 1013 English Composition I

This course emphasizes the process of writing clear, concise, developed expository prose through practice and class discussion of writing. Preparation of regularly scheduled papers, including a research assignment, is required.

119830/ENGL 1023 English Composition II **Prerequisite:** 119830/ENGL 1013

This class offers an introduction to the critical interpretation of literature. Through lectures, class discussions, library research and writing assignments, students acquire an ability to analyze literary works.

FAYETTEVILLE ADVANCED SPATIAL AND SERVICE TECHNOLOGY CENTER

<http://fasst.fayar.net>

FASST is available to West Campus students as a complimentary course to any career/technical program of study. It can be particularly beneficial to students involved in their senior project. Students in every career/technical program are highly encouraged to take FASST.

Who should take a FASST class? Any student who enjoys helping the community and wants to know more about technology in a safe, self-paced environment. **Students in FASST must be self-motivated and able to keep focused on their projects.** FASST is designed for any level of student from the very basic to the high tech guru. The FASST classroom is designed to help the student prepare for real world problem solving while giving them a safe area to explore their ideas without real world consequences. The materials in the classroom are designed to build academic, technical, and social skills needed for life outside the classroom environment.

Students who take FASST will have the opportunity to learn what is being done in the workplace using current technology. Students also build job skills and creative thinking skills, develop community relationships, and demonstrate the ideas and principles learned in the FASST classroom.

001733 FASST I: Fayetteville Advanced Spatial and Service Technology Center (10, 11, 12)
1 Year, 1 Unit
Credit: Elective

This technology-based course provides students with the opportunity to develop solutions for a wide range of problems currently affecting our school and local community. Each student will be responsible for helping the school and community in real world problem solving. Students will establish individual projects and work towards completing the project goals. Students also will have group projects to develop teamwork and solve problems too complex for individual projects. Students will accomplish these goals through the use of numerous in-class tools, including Microsoft Office, Photoshop, Geomedia, Solid Edge, 3D Graphics Software, Front Page, Global Information Software, and Global Positioning Software.

001833 FASST II: Fayetteville Advanced Spatial and Service Technology Center (10, 11, 12)
1 Year, 1 Unit
Prerequisite: FASST I
Credit: Elective

Students in this course help teach and train students enrolled in the FASST I classroom as well as work on more complex community based projects. FASST II students should have a technical understanding of software used in the classroom and work to help others develop their skills. Students in FASST II will be responsible for team building, project coordination, and organizing group projects. Students who take this course learn to help others in the classroom while developing leadership and organizational skills needed for the FASST III community environment.

001933 FASST III: Fayetteville Advanced Spatial and Service Technology Center (10, 11, 12)
1 Year, 1 Unit
Prerequisite: FASST II with Instructor approval
Credit: Elective

FASST III is a course designed to extend and apply the knowledge gained in the FASST I and II classroom. FASST III students will assume various managerial roles in the classroom. Students who enroll in this course will be responsible for team based projects as well as completing the more complex problems that may arise in the project. Students in this course will focus mainly on working in the community and being a liaison between the team members and community leaders. FASST III students must be highly motivated, responsible, and dedicated to providing positive relations in the community.

FOOD PRODUCTION MANAGEMENT AND SERVICES

<http://fayar.net/west/dept/culn/index.htm>

To graduate from West Campus with a complete program of study a total of eight semesters are to taken from a technical area of study.

493012 Food Production Management and Services (10, 11, 12) 18 Weeks, 1 Unit

Emphasis in this course is given to the development of competencies related to employability; technology in food production, management, and services; sanitation and safety, nutrition as related to food service; serving of food; use, care, and storage of large and small commercial food service equipment; menu planning; and modified diets.

493016 Leadership & Service Learning 9 Weeks, ½ Unit

The following topics are covered:

- Technology Skills/Professional Portfolios
- Family, Career and Community Leaders of America
- Service Learning
- Leadership...what is it?
- Developing Positive Leadership Qualities
- Effective Communication
- Conflict Management/Team building

493011 Foods & Nutrition 9 Weeks, ½ Unit

The following topics are covered:

- Nutrition
- Weight Control
- The Food Consumer
- Food Technology
- Microwave Cookery
- Kitchen Organization & Equipment
- Safety & Sanitation
- Menu Planning
- Serving and Eating Food
- Food Production
- Eating Away from Home

493004 Facilities Management & Service (10, 11, 12) 18 Weeks, 1 Unit

This course is designed to provide students with information and work related experiences in the occupational area of hotel/resort management, maintenance and services.

493014 Housing and Interior Design 9 Weeks, ½ Unit

The following topics are covered:

- Housing Needs
- Construction
- Furnishing and Design
- Maintenance, Safety, and Security
- Careers



493022 ProStart I (10, 11, 12)
18 Weeks, 1 Unit

ProStart I is the first part of a two-year industry based program that prepares students for careers in the restaurant and foodservice industry. After completion of ProStart I the student has the option to take ProStart II, complete 400 hours of hospitality related work experience, take and pass the ProStart exam, and receive national HBA/ProStart Certification.

493023 ProStart II (11, 12)
18 Weeks, 1 Unit

ProStart II is the second part of a two-year industry based program that prepares students for careers in the restaurant and foodservice industry. Upon completion of ProStart I & II, 400 hours of hospitality-related work experience, and successfully passing the ProStart exam, the student can receive national HBA/ProStart Certification.

493017 Lodging Management I (FACS) (10, 11, 12)
18 Weeks, 1 Unit

Lodging Management I is the first part of a two-year industry based program that prepares students for careers in the hotel/resort industry. Upon completion of the course, successfully passing the Lodging Management exam, and completion a hospitality internship, the student can receive national HBA/Lodging Management Certification.

493018 Lodging Management II (FACS) (11, 12)
18 Weeks, 1 Unit

Lodging Management II is the second part of a two-year industry based program that prepares students for careers in the hotel/resort industry. Upon completion of the course, successfully passing the Lodging Management exam, and completion a hospitality internship, the student can receive national HBA/Lodging Management Certification.

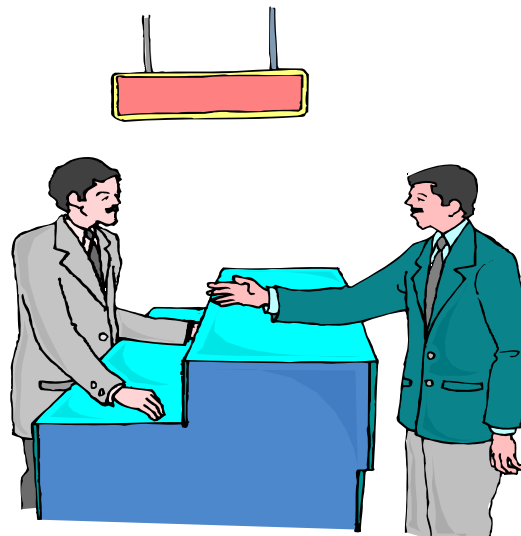

A West Campus student was a finalist and scholarship winner in the Spring 2002 Johnson and Wales National Recipe Contest.

Culinary Arts students served the Fayetteville High School Fall 2002 football banquet at the Fayetteville Towne Center.

At the Skills USA VICA Competition West Campus captured the following awards: 3rd place in Culinary Arts, 1st and 2nd place in Commercial Baking, and 2nd and 3rd place in Food and Beverages.

West Campus captured the following awards at the ProStart Competition: 1st place in quiz bowl and ProStart.

828833 Food Production Management Apprenticeship (11, 12)

Students interested in a career in Restaurant Management are eligible to participate in the Youth Apprenticeship program. Students can earn ½ credit (180 hours per semester or 10 hours per week), or 1 credit (270 hours per semester or 15 hours per week), or 1½ credits (360 hours per semester or 20 hours per week). Students enrolled in apprenticeships must also enroll in related classes recommended by their apprenticeship teacher. **Some employers require drug testing as a condition for employment.**

GEOGRAPHIC INFORMATION SYSTEMS

PENDING STATE APPROVAL FROM DEPARTMENT OF EDUCATION

494090 Intro to GIS (10, 11, 12) **9 Weeks, ½ Unit**

Introduction to GIS/Remote Sensing is a designed to introduce students to Geographic Information Systems (GIS) and Remote Sensing (RS) technology through academic study and applied instruction. Students will be introduced to terminology and concepts relating to GIS/RS technology and will apply these concepts through the use of GIS software programs. Students will participate in structure, applied learning exercised taken from existing data sources, as well as conduct new study of these data sources through self-driven study and analysis.

494091 GIS and Remote Sensing (10, 11, 12) **9 Weeks, ½ Unit**

Skill-Based Training in GIS and Remote Sensing is designed to introduce students to the use of ArcView GIS software and software extensions through academic study and extensive applied instruction. Students will be introduced to terminology and concepts relating to ArcView GIS software and will apply these concepts through the use of industry-standard software.

494092 SPACE (12) **18 Weeks, 1 Unit**

The purpose of this class is to provide students with advanced instruction in GIS and RS technology through focused academic study and continued emphasis on applied instruction that began in the Year 2 class. While the Year 2 GIS/RS project had a small scope that was limited to the school environment, this class will provide emphasis placed on special geographic projects dealing with the local community environment that will be planned, conducted,

and presented by the student, with guidance form community/industry mentors. Students will identify a community problem or situation that may be addressed using GIS/RS technology, interview necessary residents/community personnel relevant to the situation, identify and/or collect data needed for the project, perform necessary analyses, and present finding to peers, school personnel, and community stakeholders. Within the study parameters of the school-community partnership, students will gain relevant “hands-on”, industry-specific experience and valuable career guidance information that will aid the student in either the continuing education or job placement environments.

494093 STARS (11, 12) **18 Weeks, 1 Unit**

Spatial Technology and Remote Sensing (STARS) is designed to provide students with continued instruction in GIS and RS technology. Students will receive instruction and guidance form in-class lecture with the instructor acting in a facilitator capacity on topics including skill building in industry-standard geospatial extension software and geospatial tools including global positioning systems (GPS), and continued training in GIS project management and problem solving. Each student will participate in applied learning activities with emphasis placed on planning, conducting and presenting three (3) special projects dealing with the use of GIS/RS tools and data in various career cluster groups that deal with the immediate school environment. In addition to formally presenting projects to peers, school administration and other interested parties, students will be encouraging these entities to use their solutions to improve the local school environment.

GRAPHIC COMMUNICATION/PRINTING

494096 Fundamentals of Graphic Communications **/Beginning Level Printing (10, 11, 12)** **18 Weeks, 1 Unit**

This course provides an overview of the printing industry, its basic operations and career opportunities.

494099 Offset Press Operation (11, 12) **18 Weeks, 1 Unit**

This course provides an overview of offset duplicator operation through a series of tasks and simulations that build entry level skills.

494095 Electronic Imaging (11, 12) **18 Weeks, 1 Unit**

This course provides an overview of basic typography, layout design, desktop publishing and operating. It requires production of visual using electronic illustrations and text.

The open and closing team placed second at the Skills USA VICA competition in Hot Springs in 2002. Last year the print shop purchased a state-of-the-art computerized paper cutter to use in the shop as well as a collator that has the only GUI (Graphical User Interface) pad now in use in the U.S.

Sabra Whittenburg, printing instructor, received the National Outstanding Teacher Award, for the Trade and Industrial Division of the Association for Career and Technical Education for 2002.

HEALTH AND P.E.

517533 Physical Education (10, 11, 12) **9 Weeks, ½ Unit**

This course is offered the 1st 9 weeks of the fall semester and the 2nd 9 weeks of the spring semester. The course focuses on lifetime sports such as golf, tennis, fitness (weight training, jogging, etc.).

528033 Health Education (10, 11, 12) **9 Weeks, ½ Unit**

This course is offered the 2nd 9 weeks of the fall semester and the 1st 9 weeks of the 2nd semester. The course focuses on mental and social health, basic structure and functions of the human body (emphasis on fitness), and units on the danger of tobacco, alcohol, and drugs.

HORTICULTURE

<http://fayar.net/west/dept/hort/index.htm>

Courses are 90 minutes/day for 18 weeks. Courses will be specific to the horticulture field and will include soil evaluation, crop/vegetable growth, marketing, fertilization, lawn care, landscaping, and greenhouse operations. Students will be involved in Future Farmers of America. Courses involve hands-on training, plus various field trips.

491028 Intro to Horticultural Science (10, 11, 12) **9 Weeks, ½ Unit**

This course covers basic plant systems, pest control, and the areas of greenhouse management, nursery and landscaping and turf management. This course is recommended for those students interested in the Horticulture program of study.

847633 Horticulture: Plant and Soil Science (10, 11, 12) **9 Weeks, ½ Unit**

This course covers basic functions of plant systems, binomial naming of plants, careers in plant science, soil types, and soil mixtures.

847733 Horticulture: Green House Management (10, 11, 12) **9 Weeks, ½ Unit**

This course teaches the basic principles of the greenhouse from construction to heating and the different crops grown plus the time frame for production of greenhouse crops.

848233 Horticulture: Small Gas Engines (10, 11, 12) **9 Weeks, ½ Unit**

This course teaches the tools, identification, inspection, and principles of operation of both 2-cycle and 4-cycle engines. Trouble shooting different systems and overhauling the 4-cycle engine will be covered.

848833 Turf Grass Management (11, 12) **9 Weeks, ½ Unit**

This course teaches plant science, pest, wildlife, water and waste management, turf grasses, disease and insect control, equipment and maintenance, human resources, and financial management.

848733 Horticulture: Landscape Design, Installation and Management (10, 11, 12) **9 Weeks, ½ Unit**

This course gives the student skills in managing various landscape businesses. Plant identification and selection, tools and equipment maintenance, and hands-on skills are emphasized. It is recommended that an introductory horticulture course before taking this course.

491011 Agricultural Science (10, 11, 12) **9 Weeks, ½ Unit**

This course provides students with an overview of the agricultural science program of study. A brief introduction is give to each ear included in the total Agricultural Education program, so that students can then decide in which areas they are most interested. A significant port of the course is devoted to the National FFA Organization and Supervised Agricultural Experience Programs.

491030 Managing Our Natural Resources (10, 11, 12) **9 Weeks, ½ Unit**

This course offers students a chance to explore natural resources and develop knowledge and skills to use them wisely now and in the future. Resources studied include soil, water, and air, forests, energy, minerals and metals, and fish and wildlife. The use of natural resources for outdoor recreation will also be covered. Careers in natural resources will be researched, and environmental issues debated.

848933 Horticulture: Apprenticeship (11, 12)

This apprenticeship program is designed to prepare high school juniors and seniors for careers in horticulture. Students can earn ½ credit (180 hours per semester or 10 hours per week), or 1 credit (270 hours per semester or 15 hours per week), or 1½ credits (360 hours per semester or 20 hours per week). Students enrolled in apprenticeship must also enroll in related classes recommended by the apprenticeship teacher. **Some employers require drug testing as a condition for employment.**

INDEPENDENT/GUIDED STUDY

001133 Independent Study (9, 10, 11, 12) 9-18 Weeks, ½ Unit per course

Students may petition for enrollment in these classes through their principal/counselor's office and the work is completed as an independent study. Additionally, students may take these courses as a second class during the summer school offering at West Campus. The course work is considered a guided study (teacher directed) and class/seat time is required.

| | |
|--------------------------------|----------------------|
| Algebra | Geometry |
| Algebra II | Government |
| Art | Health Education |
| Biology | Oral Communication |
| Consumer Education (Economics) | Personal Finance |
| Economics | Physical Science |
| English | Spanish I |
| Environmental Sciences | Themes in Literature |
| Ethnic Studies | World History |
| Geography | |

First and second semester courses are available separately.

MATHEMATICS

http://fayar.net/west/dept/math/mathematics_at_wc.htm

238733 Algebra I (9, 10) 18 Weeks, 1 Unit

This course will focus on “strands” of algebra and functions, geometry and trigonometry, statistics and probability and discrete mathematics as defined by the state frameworks. The four strands are connected across units by mathematical habits of mind such as visual thinking, searching for and describing patterns, making and checking conjectures, reasoning, inventing mathematics and providing convincing arguments. The strands are linked by fundamental themes of data, representation, shape and change.

238933 Algebraic Connections (10, 11, 12) 18 Weeks, 1 Unit Prerequisite: Alg. I

This course will cover advanced algebra topics from probability, statistics, functions and graphs to other discrete mathematics topics. This course uses various strategies, including technology, to further develop algebraic understanding and its applications. This course meets the third year math requirement for graduation. Students could choose to follow this course with Algebra II. Completion of Algebra II is recommended for students entering college.

For more high school math offerings, see page 33.

237533 Algebra II (10, 11, 12) 18 Weeks, 1 Unit Prerequisite: Algebra I

This course includes the structure of both the real and complex number systems; coordinate geometry; relations and functions; rational and irrational expressions; polynomial (including linear and quadratic) functions; systems of equations and inequalities; linear, quadratic, and absolute value equations and inequalities. Extensions may include selected items from statistics, matrices, exponential and logarithmic functions.

248033 Geometry (10, 11, 12) 18 Weeks, 1 Unit Prerequisite: Alg. I or Integrated A/B

In this course, concepts are introduced visually, analytically, inductively, and deductively. Students will use tools of geometry to perform investigations and learn by doing. Skills will be acquired in critical thinking, problem solving, properties of geometric figures, parallel and perpendicular lines, Pythagorean Theorem, area volume, as well as compass and straightedge construction of geometric figures. Projects are assigned.

Trigonometry will be offered by arrangement with advisor.

MEDICAL PROFESSIONS

<http://fayar.net/west/dept/med/index/htm>

494129 Introduction to Medical Professions–Part 1 (10, 11, 12) 9 Weeks, ½ Unit (Core Course)

This course is designed to provide students with basic information and skills needed for a career in a health care field and includes the following:

- Health care delivery system
- Professionalism, ethics and legalities of medicine
- Health care history & medical events
- Health care careers
- Interpersonal and communication skills
- Introduction to medical terminology & abbreviations
- Career, Technical and Professional Organization

494131 Introduction to Medical Professions-Part 2 (10, 11, 12) 27 Weeks, 1 ½ Units (Elective Credit)

This course will include the following:

- Medical Math
- Nutrition and Health
- Human Growth & Development
- Classification of Disease
- Introduction to Anatomy & Physiology
- Job Seeking Skills
- Geriatric Care

494128 Medical Procedures (11, 12) 18 Weeks, 1 Unit (Core Course) Prerequisite: Introduction to Medical Professions Education

Students will develop specific skills needed in the health care professions. This will include:

- Basic infection control
- Safety
- First Aid/CPR
- Dental Science Skills
- Nurse Assistant Skills
- Medical Office Assistant Skills
- Physical Therapy Skills
- Animal Health Care

494132 Medical Terminology (11, 12) 9 Weeks, ½ Unit Prerequisite: Introduction to Medical Professions Medical Procedures

This course gives an overview of how medical terms are formed from root words, prefixes, suffixes, and combining forms. It explores the rules of pronunciation and spelling, using drawings, diagrams, and definitions to relate human anatomy and physiology. Students may receive concurrent high school/college credit through Northwest Arkansas Community College.

868035 Medical Professions: Dental Assisting I (10, 11, 12) 36 Weeks, 2 Units

This course offers practical application of dental theory and skills through actual chair side assisting with a dentist and patient in the clinical setting at West Campus.

868033 Medical Professions: Dental Assisting II (11, 12) 36 Weeks, 2 Units Prerequisite: Dental Assisting I

This course offers continued practical application of dental theory and skills through actual chair-side assisting with a dentist and patient in the clinical setting at West Campus. After evaluation of clinical training, students may be placed in dental offices for additional training in specialty areas.

494125 Human Anatomy & Physiology (11, 12) 18 Weeks, 1 Unit (Core Course) Prerequisite: Introduction to Medical Professions Medical Procedures Medical Terminology

The course focuses on anatomical/physiological systems of the body as well as the diseases of those systems.

494126 Medical Professions: Career Specialization (12) 18 Weeks, 1 Unit Prerequisite: Introduction to Medical Professions Medical Procedures Medical Terminology

This course offers Certified Nurse Assistant certification during the school year and also provides clinical training in area health care facilities.

867533 Medical Professions Apprenticeship (11, 12) Prerequisite: Intro to Med Pro Ed Medical Procedures

Students interested in Medical Professions Education are eligible to participate in the Youth Apprenticeship program. Jobs and skills training are designed specifically to prepare students for future employment. Students will have an opportunity to interview for jobs at appropriate work sites where they will work part of each day. Students can earn ½ credit (180 hours per semester or 10 hours per week), or 1 credit (270 hours per semester or 15 hours per week), or 1½ credits (360 hours per semester or 20 hours per week). Students enrolled in apprenticeships must also enroll in related classes recommended by their apprenticeship teacher. **Some employers require drug testing as a condition for employment.** Contact Mrs. Bingham at 444-3058 for additional information about this new opportunity.

PRE-ENGINEERING

<http://fayar.net/west/dept/preengineering/index.html>

This is a three year sequence of course which, when combined with traditional mathematics and science course in high school, introduces students to the scope, rigor and discipline of engineering prior to entering college. However, those not intending to pursue further formal education will benefit greatly from the knowledge and logical thought processes that result from taking some or all of the courses provided in the curriculum. These courses are taken two a year for 1 unit of credit each. Each class is 1.5 hours therefore a student can get two credits each year. The courses are:

837033 Introduction to Engineering Design (9-12)
18 Weeks, 1 Unit
Prerequisite: Geometry

Introduction to Engineering Design is a course that teaches problem-solving skills using a design development process. Models of product solutions are created, analyzed and communicated, using solid modeling computer design software. College credit is currently available.

837133 Digital Electronics (11)
18 Weeks, 1 Unit
Prerequisite: Must be in Algebra II or have successfully completed it.

Digital Electronics is a course in applied logic that encompasses the application of electronic circuits and devices. Computer simulation software is used to design and test digital circuitry prior to the actual construction of circuits and devices. College credit is currently available.

837035 Principles of Engineering (10, 11, 12)
18 Weeks, 1 Unit
Prerequisite: Algebra I and must be in or through Geometry

This course helps students understand the field of engineering/engineering technology. Exploring various technology systems and manufacturing processes helps students learn how engineers and technicians use math, science, and technology in an engineering problem solving process to benefit people. The course also includes concerns about social and political consequences of technological change.

837233 Computer Integrated Manufacturing (11, 12)
18 Weeks, 1 Unit
Prerequisite: Introduction to Engineering Design and Principals of Engineering

This is a course that applies principles of robotics and automation. The course builds on computer solid modeling skills developed in Introduction to Engineering Design. Students use CNC (computerized milling machinery) equipment to produce actual models of their three-dimensional designs. Fundamental concepts of robotics used in automated manufacturing and design analysis are included. College credit is currently available.

837055 Engineering Design and Development (12)
18 Weeks, 1 Unit
Prerequisite: Introduction to Engineering Design, Digital Electronics, Computer Integrated Manufacturing, and Principles of Engineering

Engineering Design and Development is an engineering research course in which students work in teams to research, design and construct a solution to an open-ended engineering problem. Students apply principles developed in the four preceding courses and are guided by a community mentor. They must present progress reports, submit a final written report and defend their solutions to a panel of outside reviewers at the end of the school year.

877833 Engineering Apprenticeship (11, 12)

The Engineering Apprenticeship is designed to prepare high school juniors and seniors for careers in engineering. Students accepted for Engineering Apprenticeship will have an opportunity to interview for jobs at appropriate work sites where they will work part of each day. Students can earn ½ credit (180 hours per semester or 10 hours per week), or 1 credit (270 hours per semester or 15 hours per week), or 1½ credits (360 hours per semester or 20 hours per week). Students enrolled in apprenticeships must also enroll in related classes recommended by their apprenticeship teacher. **Some employers require drug testing as a condition for employment.**

West Campus students exceeded both math and science goals set by the Southern Region Education Board for High Schools That Work sites.

SCIENCE

http://fayar.net/west/dept/science/science_homepage.htm

320133 Earth Science (10, 11, 12) **18 Weeks, 1 Unit**

This course is recommended for students who need a physical science credit. The class will focus on the methods of earth science; changes in the earth's crust through movement, weathering, and erosion; and the use of maps and other tools to chart the earth's landforms. The management of the earth's resources will also be investigated. The class will describe the geologic history of the earth from its formation to the present day form. A detailed study of oceanography and astronomy will accompany the study of the earth's atmosphere and the development of local weather patterns.

318533 Biology (10, 11, 12) **18 Weeks, 1 Unit**

This course is a basic biology course examining organisms. Students will develop an understanding and appreciation of the way the human organism and other organisms interrelate. The course is presented by lectures, videos, laboratory work, and field trips. Students will learn study skills, laboratory skills, observation skills, and the ability to work in groups. Students are evaluated based on an observation of laboratory work, daily assignments, and written tests.

NorthWest Arkansas Community College (11, 12)

Fayetteville Juniors and Seniors may enroll in the following English courses at NWACC. See "Concurrent" Step-Ahead (page 56) for more information.

319530/BIOL1544 **Biology A/ Principles of Biology I**

This course is an introductory college course in biology that surveys various levels of organization from atoms to biomes. Topics of study include problem-solving by means of the scientific method, the chemistry of life, cellular and sub-cellular biology, metabolism, cell reproduction, genetics, animal organization and survey, and basic ecological and evolutionary principles.

328033 Chemistry (10, 11, 12) **18 Weeks, 1 Unit**

Prerequisite: Physical Science

This course studies the structure, composition, and properties of matter and the chemical changes that matter undergoes. Particular emphasis will be placed on chemistry in the workplace environment which includes production, quality control, and materials safety. "Wet" and computer laboratories, written assignments, tests, and portfolio/research problems are required.

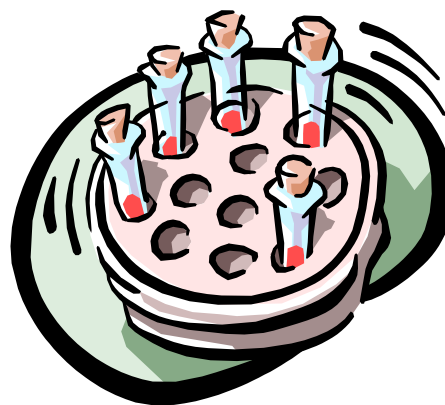

329033 Physical Science (10, 11, 12) **18 Weeks, 1 Unit**

This is a standard course preparing students for more advanced courses such as chemistry and physics. Mechanics, statics, motion, matter, and energy are all covered.

327533 Physics (10, 11, 12) **18 Weeks, 1 Unit**

Prerequisite: Algebra I, Geometry, and Physical Science

This class studies matter, movement and energy such as heat, light, electromagnetism, and the nuclear processes. Laboratory exercises including computer assisted activities, and the study of the world around you will be covered. Evaluation of student performance will be based on written and oral examinations, laboratory participation, and special projects.

SOCIAL STUDIES

419533 American Government (10, 11, 12)
9 Weeks, ½ Unit

This course covers a survey of various topics in American Government. It meets the Civics/Government credit requirement.

429033 World History (10, 11, 12)
18 Weeks, 1 Unit

This course covers a survey of major cultures and events from the Stone Age to early modern Europe.

437633 U.S. History I (10, 11, 12)
18 Weeks, 1 Unit

This course begins with the discovery of America through the colonial period to statehood and finishes with the Civil War.

437733 U.S. History II (10, 11, 12)
18 Weeks, 1 Unit

This course is a standard U.S. History course stressing social, political, and economic aspects, 1872 to present.

SPECIAL EDUCATION SERVICES

West Campus offers those special education services guaranteed by the Federal government and the State of Arkansas. Programs are available to provide assistance to any student who meets state and federal regulations for these programs. Such programs may include speech and

language therapy, occupational therapy, physical therapy and/or specialized instruction in academic and/or emotional areas. All students will be required to enroll in a career and technical class. Special education testing may be requested by contacting the office of Special Education.

WELDING

494157 Metal Fabrication (10, 11, 12)
18 Weeks, 1 Unit

A basic introduction into all areas of welding shop with emphasis on safety and basic operation of SMAW, GMAW, gas welding, gas cutting, and plasma cutting.

494155 Gas Metal Arc Welding (GMAW)
(10, 11, 12)
18 Weeks, 1 Unit
Prerequisite: Metal Fabrication

An introduction and the complete coverage of all GMAW processes.

494158 Shielded Metal Arc Welding (SMAW)
(10, 11, 12)
18 Weeks, 1 Unit
Prerequisite: Metal Fabrication

An introduction and the complete coverage of all SMAW processes.

494156 Gas Tungsten Arc Welding (GMAW)
(10, 11, 12)
18 Weeks, 1 Unit
Prerequisite: Metal Fabrication

An instructional program that prepares individuals to apply technical knowledge and skills to unite or separate metal parts by heating, using a variety of techniques and equipment. Emphasis of this course will be the use of gas tungsten arc welders.

839133 Welding Apprenticeship (11, 12)
Prerequisite: Metal Fabrication

The Welding Apprenticeship program is designed to prepare high school juniors and seniors for careers in welding. Students will have an opportunity to interview for jobs at appropriate work sites where they will work part of each day. Students can earn ½ credit (180 hours per semester or 10 hours per week), or 1 credit (270 hours per semester or 15 hours per week), or 1½ credits (360 hours per semester or 20 hours per week). Students enrolled in apprenticeships must also enroll in related classes recommended by their apprenticeship teacher. **Some employers require drug testing as a condition for employment.**

For more high school social studies offerings in the district, see page 43.

RAMAY JUNIOR HIGH COURSE DESCRIPTIONS

AGRICULTURE

844033 Agri Science and Technology (9) 1 Year, 1 Unit

This course is based on the applied and technical study of the various segments of the agriculture industry. Basic animal, plant, and soil sciences and agriculture mechanical skills are introduced. The course also deals with FFA and agriculture careers. Students are required to keep a notebook and master a range of skills.



ART

630183/630193 Art I (8, 9) 1 Year, 1 Unit

This course in visual art focuses on creativity, art skills, problem solving, art history, critical thinking and the value of work. Students develop skills using various art media and methods. They learn to apply art elements and principles of design to their own creations. Art criticism and study of artists/art styles are integrated into units that also include hands-on studio projects. There is a \$13 art fee that covers students' sketchbook, oil pastel set, and some consumables. For 9th graders, this course more than fulfills graduation fine arts credit.

630192 Art II (9) 1 Year, 1 Unit

Prerequisite: Teacher approval, based on student skill and past performance

This course requires young artists to bring high interest and self-motivation to class. Building on the skills developed in Art I, students will further explore various art media to express ideas visually. Learning related art history (artists and styles) is incorporated into the studio units. There is a \$14 materials fee that helps cover consumables. Students interested in going into Studio II at FHS should keep a portfolio of art works and sketchbook. This course fulfills graduation fine arts credit.

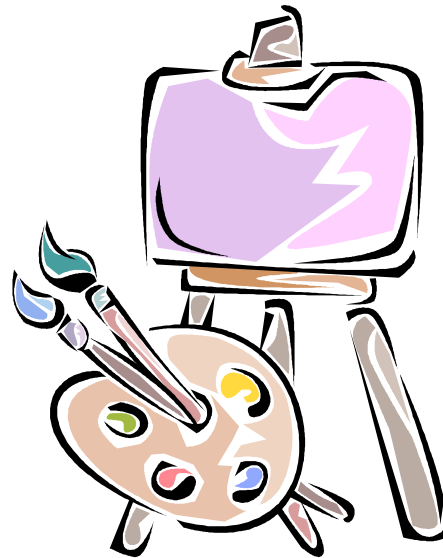

Ramay's scores on the state-required ACTAAP Benchmark Exam were 60% proficient or advanced in literacy as compared to the state level of 37% and were 37% proficient or advanced in math as compared to 24% on the state level. Ramay's scores compare favorably with other schools in the area.

ATHLETICS

- 530283 Basketball - boys (8)**
530293/510493 Basketball/P.E. - boys (9)
1 Year, ½ Unit of P.E. credit
- 530183 Basketball - girls (8)**
530193/510393 Basketball/P.E. - girls (9)
1 Year, ½ Unit of P.E. credit

The basketball program at Ramay Junior High School is designed to accomplish many things, such as:

- Building confidence
- Promoting team work
- Developing skills in basketball
- Teaching discipline
- Providing physical development
- Teaching responsibility
- Promoting sportsmanship
- Promoting school spirit

Students will sign up for athletics in the spring. Coaches will decide who will represent our school based upon grades, citizenship marks, and basketball ability. The first 2½ months of the program are spent in physical development and skill training for the game of basketball. During the season, the athletes practice offense and defense for the upcoming game. The coaches attempt to play as many of the athletes as possible, yet remain competitive. As many “B” games as possible are scheduled for those athletes who do not play consistently during the “A” games. During the post season, students will focus upon developing the skills of dribbling, shooting, passing, and defensive work. Students also stretch, lift weights, run, and play pickup games as they continue to develop as individuals and as a team.

- 530283 Cross Country Track - boys (8)**
530293/510493 Cross Country Track/P.E. - boys (9)
530183 Cross Country Track - girls (8)
530193/510393 Cross Country Track/P.E. - girls (9)

Enrollment requires the coach’s approval. Approval is based on academic record, behavior displayed, and ability to complete distance runs. Practice consists of runs up to 3 miles and weight training. Practices are held during 7th period ending at 3:15 p.m. Students will compete in 5 to 6 races during September and October, held on Saturday mornings or after school. Participants must have a physical and training shoes.

Ramay athletics continues to build competitive programs, football, basketball, volleyball, track, and cross-country, towards conference contenders. For the past 10 years Ramay’s track program has been outstanding, winning 14 boys conference and regional championships and 10 girls conference and regional championships. The 8th grade football team was undefeated this year. Perfect season: 10-0!!!

- 530283 Football (8)**
530293/510493 Football/P.E. - boys (9)
1 Year, ½ Unit of P.E. credit

Enrollment in this program requires coaches’ approval. Approval is based on academic record, discipline record, and behavior displayed in school. Arkansas Activities Association eligibility requirements also must be met. Practice will begin two (2) weeks prior to the start of school and, once school begins, practice will last until 5:30 p.m. during the school week. All equipment is provided except shoes and the doctor’s physical. Ninth grade students will complete a semester of physical education in the off-season of their sport.

- 530283 Track - boys (8)**
530293/510493 Track/P.E. - boys (9)
1 Year, ½ Unit of P.E. credit
- 530183 Track - girls (8)**
530193/510393 Track/P.E. - girls (9)
1 Year, ½ Unit of P.E. credit

Boys and Girls Track: Track helps develop speed, strength, endurance, cardiovascular endurance, along with learning to compete against athletes from a variety of other schools. Track athletes will be chosen with the following criteria:

- Citizenship: Only students who exhibit responsible behavior will be allowed to attend track meets.
- Athletic Ability: Track offers 14 different events so there are a lot of opportunities for participants.

BUSINESS TECHNOLOGY

810283 Introduction to Computer Technology (8)
½ Year, ½ Unit
Prerequisite: Computerized Keyboarding

This is a one-semester course designed to expose students to computer and business applications which are necessary to live and work in a technological society. The four components of Microsoft Office: Word, Excel, Access, and Powerpoint will be introduced. Emphasis is given to data entry, computer concepts and operations, integrated computer software, implications of technology in society, and ethics. The course is designed to provide students with an understanding of the business, industrial and scientific area where computers are used.

812333 Computerized Business Applications (9)
1 Year, 1 Unit
Prerequisite: Computerized Keyboarding

Computerized Business Applications is a two-semester course designed to prepare students with an introduction to business applications that are necessary to live and work in a technological society. Emphasis is given to hardware, concepts, and business uses of applications. The business applications covered are word processing, graphics, spreadsheet, database, and electronic mail.

CAREER ORIENTATION/KEYBOARDING

850183 Career Orientation (8)
½ Year, ½ Unit

Students in Arkansas are required to take this course for a minimum of one semester in the eighth grade. Career Orientation follows vocational curriculum. This course is required as a hands-on, activity based, career exploration course. It provides eighth grade students the opportunity to explore the world of work in relation to their own interests and abilities.

812033 Computerized Keyboarding Applications (8)
½ Year, ½ Unit
Prerequisite: Computerized Keyboarding

Computerized Keyboarding Applications is a one-semester course designed to further develop keyboarding skills. Emphasis is placed on the following: speed and accuracy; proofreading; producing mailable copy from rough draft; and the composition of various types of business communications.



Ramay has an active Peer Helper Program consisting of twenty-one members. The students take training for three days in July which includes the Vista Health Rope Course and activities at the Jones Family Center. Guest Speakers present at the monthly meetings throughout the year. The peer helpers attend the annual Northwest Arkansas Peer Helper Conference in the spring. They have been presenters in charge of one of the workshops the last two years. One of their many activities they enjoy is stuffing stockings for the Salvation Army.

The Family, Career, and Community Leaders of America currently has 70 members. The emphasis is on building leadership skills and carrying out community service projects. Students will go to Silver Dollar City in the spring. The student organization was honored in February by being selected to organize, present, and serve brunch to Governor Huckabee and guests. He spoke to students and faculty in an assembly and toured the school.

ENGLISH

110183 English (8) 1 Year, 1 Unit

Students will continue the writing process with emphasis on revision and development of detailed writing products. They will maintain a selected collection of their writings to show their growth as writers. In addition, they will have opportunities to share their writing with peers, teachers, and parents. Grammar and usage will be taught in the context of the writing process. Students will read and evaluate a variety of literary forms: novels, short stories, plays, poetry, and non-fiction.

110182 Pre-AP English (8) 1 Year, 1 Unit

***RAMAY JUNIOR HIGH SCHOOL CRITERIA FOR PLACEMENT IN PRE-AP ENGLISH: 1) Willingness to complete outside classroom assignments. 2) Must have a “B” average or higher in English. 3) Teacher recommendation. 4) No schedule changes will be considered during the first quarter. 5) Special requests for students not meeting the criteria for Pre-AP placement must be made directly to the Ramay principal.**

Eighth grade Pre-Advanced Placement English class will provide a strong foundation in reading, writing, speaking, and listening skills as students prepare for an AP program in high school. Depth of study, rather than a “more-is-better” approach, will focus that student on a grade-appropriate but challenging language arts study. Reading and writing skills will be stressed, and outside reading and homework will be required components of the student effort. Students will be expected to assume responsibility for all assignments (i.e., no late work). Please note: This course is NOT required for Pre-AP English in the ninth grade. However, this IS the course for those students who need, want, and thrive on challenge.

110193 English (9) 1 Year, 1 Unit

Writing will be studied as a process; much of the writing will be evaluated for effort and content rather than mechanics. Students will write for varied purposes and audiences and will be introduced to research techniques. Mini-lessons and individual conferences will help students address correct usage, mechanics, and grammar. Reading studies will include the short story, the novel, the essay, poetry, and drama. Speaking and listening skills will also be developed.

110192 Pre-AP English (9) 1 Year, 1 Unit

***RAMAY JUNIOR HIGH SCHOOL CRITERIA FOR PLACEMENT IN PRE-AP ENGLISH: 1) Willingness to complete outside classroom assignments. 2) Must have a “B” average or higher in English. 3) Teacher recommendation. 4) No schedule changes will be considered during the first quarter. 5) Special requests for students not meeting the criteria for Pre-AP placement must be made directly to the Ramay principal.**

The Pre-Advanced Placement English class will provide students with the experiences and strategies they need in an AP program. Independent reading and response to literature will be integrated with material in Pre-AP U.S. History. There will be emphasis on expository writing and outside reading. Pre-AP teachers will work with the other junior high and high school colleagues in selecting appropriate materials. The coursework will be demanding. A signed contract and summer reading are required. Placement will be by student choice, but the class standards and student and parent requirements must meet the criteria of the Pre-AP program. A student contract will be required for placement in the class. This course is NOT a prerequisite for the Honors American Studies class in the 10th grade.

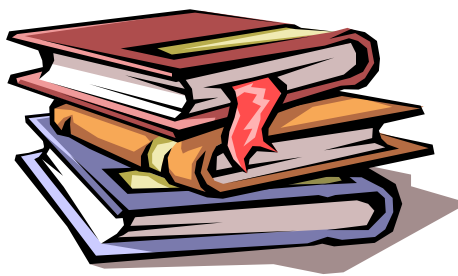

ENGLISH AS A SECOND LANGUAGE

English as a Second Language (ESL) (8, 9)

English as a Second Language (ESL) classes at Ramay serve students who are non-native speakers of English. Students receive small group instruction to

improve their communication skills based on testing results and their individual needs.

FAMILY AND CONSUMER SCIENCES

820183/820193 Family and Consumer Science (8, 9) 1 Year, 1 Unit

This course is designed to provide students with the basic information and skills needed to function effectively as an individual and as a consumer. Topics covered:

- Needs and growth patterns of children
- Techniques of discipline
- Clothing selection
- Garment construction
- Money management
- Use of credit cards and banking services
- Nutrition and food selection
- Meal planning and preparation
- Family and individual health
- Principles and elements of design
- Arrangement of living space
- The computer as a home appliance
- Home management
- Relationships



The above list will be supplemented through guest speakers, field trips, videos, and hands-on experience.

The Ramay Student Council is an active group of students. They work hard during the year on many projects. They paid for the logos on the hall and locker court walls, co-sponsored the “Miles for Mykka” event, raised money for the Twin Towers Fund, and sponsored this year’s American Pride Day Assembly to commemorate 9/11.

FOREIGN LANGUAGE

720233 French I (8*, 9) 1 Year, 1 Unit

In French I, students will learn to communicate in French on a variety of topics. They will be able to ask and answer questions about themselves and their possessions, friends and family, and daily activities and leisure pastimes. They will be able to express themselves accurately in a variety of situations such as making introductions, ordering a meal, shopping, socializing with peers, and making plans. To sharpen language skills, class activities include oral and written practice, individual and group study, and frequent review. Students will learn about the customs and cultures of the French-speaking countries through the use of culturally authentic videos and tapes.

***To take French I as an 8th grader, the student must have a “B” average or better for the 7th grade, with no grade below a “C” and a “B” for both semesters of the 7th grade Language Arts.**

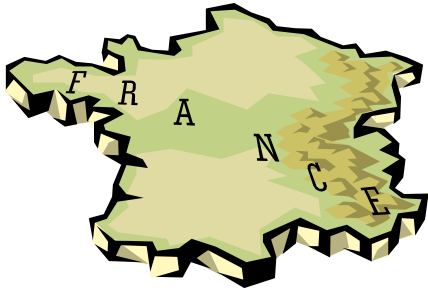

720333 French II (9) 1 Year, 1 Unit Prerequisite: French I

French II is a continuation of French I with emphasis on the five language skills: speaking, listening comprehension, reading, writing, and culture. Grammar study is more complex, and vocabulary is expanded to include such topics as school, professions, meals, food, shopping, entertainment, sports, health, and house and home. Emphasis continues to be on applying all grammar and vocabulary skills to conversation and to writing well-organized compositions in French. Class time is used to practice speaking and listening skills; therefore students must assume more responsibility for mastery of text material at home. Grades are based on written or oral assignments, performance on tests, and oral interviews. Thirty minutes per day for homework is expected for the average student. This course is recommended for students who have recorded grades of “C” or better in French I.

730833 German I (8*, 9) 1 Year, 1 Unit

In German I, a beginning course, students will learn to communicate accurately in German on a variety of topics. They will be able to ask and answer questions about themselves and their possessions, about friends and family, and about their daily activities and leisure pastimes. They will be able to function in German in a variety of situations such as making introductions, ordering a meal, shopping, socializing with peers, and making plans. To sharpen language skills, class activities will include oral and written practice, individual and group study, and frequent review. Students will learn about customs and cultures of the German-speaking countries through the use of culturally authentic videos and tapes.

***To take German I as an 8th grader, the student must have a “B” average or better for the 7th grade, with no grade below a “C” and a “B” for both semesters of the 7th grade Language Arts.**

730933 German II (9) 1 Year, 1 Unit Prerequisite: German I

German II is a continuation of the presentation of the basic grammar of the language and culture not covered in German I. In the classroom listening, speaking, reading, and writing skills are developed with emphasis on communicative activities. Students must assume more responsibility for mastery of vocabulary than students taking German I. A minimum of twenty minutes of homework per night is required. Grades are based on test and quiz performance, homework, class participation, projects, and oral interviews. This course is recommended for students who have recorded grades of “C” or better in German I.



711283/711293 Narrative Spanish (8, 9)
1 Year, 1 Unit

This course is designed for those students who want to learn basic conversational Spanish without the emphasis on grammar studies included in Spanish I. This would be suitable for students who request Spanish as one of their three electives in the 9th grade but who are not ready for regular Spanish I. The class would emphasize the conversational skills that students might need in the workplace, with some attention given to reading, writing, and cultural skills. The class is taught mainly by storytelling with the use of American Sign Language, songs, projects, and job-site simulations. Students will be speaking Spanish (with a limited vocabulary) almost immediately. Most homework will be in preparation for oral presentations to demonstrate mastery of what the class is learning.

711633 Spanish I (8*, 9)
1 Year, 1 Unit

In this beginning language course, students will learn to communicate in Spanish on a variety of topics. They will be able to ask and answer questions about themselves, friends and family, daily activities and pastimes, and possessions. They will be able to accurately express themselves in a variety of situations such as introductions, ordering a meal, shopping, socializing with peers, and making plans. To sharpen language skills, class activities will include oral and written practice, individual and group study, and frequent review. Students will learn about the customs and cultures of the Spanish-speaking countries through the use of culturally authentic videos and tapes.

***To take Spanish I as an 8th grader, the student must have a “B” average or better for the 7th grade, with no grade below a “C” and a “B” for both semesters of the 7th grade Language Arts.**

Since 1991, the Ramay Foreign Language Club has sponsored an annual Penny Drive to raise money for local charities. As a result, a total of over **\$18,000** has been donated to organizations such as Children’s House, the Salvation Army, the Red Cross, the Rape Crisis Center, the Northwest Arkansas Free Health Clinic, and the Ramay Counseling Fund.

711733 Spanish II (9)
1 Year, 1 Unit

This course is a continuation of the presentation of the basic grammar and vocabulary of the language begun in Spanish I. Speaking, listening, reading, and writing skills are developed with emphasis on communicating activities. Students are expected to study vocabulary daily, complete written exercises, and prepare oral assignments. There are frequent quizzes as well as chapter tests. Discussion of Hispanic cultures emphasizing Central and South American and the Caribbean will occur throughout the year. (This course is recommended for those who made a C or higher in Spanish I.)

740183/740193 Survey of Foreign Languages (8, 9)
1 Year, 1 Unit

This year-long survey is a course introducing students to a variety of languages. Students will learn and practice basic conversational foreign language. Students will also study the history of language, the holidays that are important to different cultures, and the famous people associated with certain languages. This course does not fulfill high school honors graduation requirements.



HEALTH

520193 Health (9) ½ Year, ½ Unit

This is a one-semester course that counts toward high school graduation. The course is designed to help students achieve a high level of health in the areas of physical, mental, and social health. Topics covered include: total health, stress, relationships, nutrition, physical fitness, drugs, alcohol, tobacco, communicable and non-communicable diseases, consumer health, human sexuality, environmental health, and basic first aid. Emphasis will be on developing a healthy lifestyle that will benefit the student now and in the future.



The Ramay Knowledge Master team is made up of 8th and 9th grade GT students. They practice every week and in December and in April compete in 200 question computer generated international contests. The competitions emphasize teamwork and quick analysis of broad subject matter.

Ramay's Quiz Bowl team placed 2nd in the 5A West tournament last year, which qualified them for the state competition in which they placed 4th. Ramay students were recognized for their speed and accuracy. All students can try out for the Quiz Bowl team. This year's enthusiastic team includes five 8th graders and four 9th graders who practice every Tuesday after school.

Currently Ramay has three Odyssey of the Mind teams. The mission of the Odyssey of the Mind is to nurture and develop creativity. The seven-member teams work for five months to produce an original solution to one of the five long-term problems. This year teams are working on the classic structure and vehicle problems. Congratulations to these students for their creative efforts. They will present their solutions in regional competitions in March.

In October, ninth grade GT students attended the fourth annual Celebrate Excellence Conference at the Jones Center and Ramay students presented workshops on Quiz Bowl and Independent Study. This conference, organized by the superintendents of 5A West schools, recognizes the outstanding extracurricular opportunities for high school students.

Seven Ramay students were invited to join the University of Arkansas Upward Bound, a college preparatory program.

MATH

230183 Foundations of Algebra (8)

1 Year, 1 Unit

Prerequisite: Pre-algebra

This course will develop the foundation of algebraic understanding for the subsequent formal study of algebra. Students will explore relations among quantitative variables and use numerical tables, graphs, symbolic expressions, and verbal descriptions to describe and predict the patterns of change in variables. Students will work with various representational forms and strategies (including the use of graphing calculators and other technologies) to recognize the patterns of change associated with linear, exponential, and quadratic functions and to solve common problems involving these functions. This course applies geometry, probability, statistics, and measurement concepts that develop algebraic reasoning.

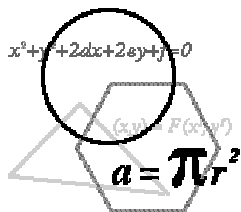

230333 Algebra I (9)

1 Year, 1 Unit

Prerequisite: Foundations of Algebra

Students will develop understanding of and skills with: the language of algebra; the use of properties of equality to solve linear and quadratic equations and inequalities; concepts of functions, relations, and patterns; the use of tables and graphs to represent data, make predictions, use simple matrices, use and apply linear, quadratic, and exponential functions; and polynomial operations and factoring of polynomials. Graphing calculators and other technologies will be used to develop and apply algebraic concepts to solve mathematical and real world problems.

230282 Honors Algebra I (8)

1 Year, 1 Unit

Prerequisite: Pre-algebra

This course is designed for students who have demonstrated proficiency in pre-algebra and problem solving skills. The study of Honors Algebra I requires a high level of motivation to learn and good organizational skills. Honors Algebra I is a more rigorous approach to concepts in the Algebra I curriculum, which includes: solving equations, factoring, polynomials, graphing, rational expressions, systems of equations, and the appropriate use of the TI graphing calculator and other technologies.

230932 Honors Algebra II (9)

1 Year, 1 Unit

Prerequisite: Honors Algebra I

This course is designed for students who have been successful in studying Honors Algebra I. Placement in this course is by teacher approval only. Honors Algebra II is a more rigorous approach to topics in the Algebra II curriculum. This course includes the structure of the real and complex number systems, coordinate geometry, relations and functions, rational and irrational expressions, matrices, linear and quadratic polynomial functions, systems of open sentences, conic sections, logarithms, and linear, quadratic, and absolute value equations and inequalities. Additional topics on matrices, graphing, complex numbers, and linear programming are included. Students planning to take AP Calculus should take this course to be sufficiently prepared.

240483/240533 Honors Geometry (8, 9)

1 Year, 1 Unit

Prerequisite: Honors Algebra I

This course is designed for students who have successfully completed Honors Algebra I. Students make conjectures based on observations including inductive reasoning. This technique is used to introduce and then reinforce the characteristics and properties of all the basic two and three dimensional geometric figures. Honors Geometry is a more rigorous approach to topics in the geometry curriculum. It includes critical thinking, problem solving, parallel and perpendicular lines, radicals, area and volume, in addition to compass and straight edge construction of geometric figures. Honors Geometry is a prerequisite for Honors Algebra II. Students must maintain a 3.0 average in Honors Geometry to be recommended for placement in Honors Algebra II at the high school.

The Ramay Knights of the Round Table Chess Club consists of 20 active members in grades 8 and 9. This club meets bi-weekly after school and competes in regional and state tournaments four times a year.

In 1999, 2000, and 2001, Ramay was awarded the trophy for the Scholastic State Tournament. In March 2002, a Ramay student took 1st place for the Arkansas State Tournament in Junior High Division. Currently, we are proud to have our own nationally ranked chess champion who placed in the United States top 20 players in the 18 and under Scholastic division. This player tied for sixth place in the nation in the Denver Invitational and the U.S. Open.

Open your mind by discovering the world of chess and explore new horizons while having fun.

MUSIC

610183 Concert Band (8) **1 Year, 1 Unit (Fine Arts Credit)**

Students who have achieved the minimum requirements in beginning band will be chosen to participate in the Concert Band. The Concert Band performs at various events throughout the year including the winter and spring concerts. Emphasis is placed on developing individual skills while learning to perform in an ensemble setting. This group will have opportunities to compete individually and corporately at different events throughout the year.

610292 Symphonic Band (9) **1 Year, 1 Unit (Fine Arts Credit)**

Students who have achieved the minimum requirements in the Concert Band will be chosen to participate in the Symphonic Band. The band marches in the fall and performs at football games, parades, and marching contest. Students may audition for flagline or drum major in late spring and participate in these auxiliary groups with the marching band in the fall. The Symphonic Band performs at various concerts and events throughout the year. Members will have opportunities to compete individually and corporately at different events throughout the year. This group also performs in the winter and spring concerts each year.

We at Ramay are very proud of the success in our instrumental music program. The Ramay Bands continue to make first divisions each year in the area of Marching, Solo and Ensemble, and Concert Contests. For the past seven years Ramay has averaged over 50 students participating in All Region Band which is the highest number of students within the region of schools that tryout.

The band performs a winter and spring concert every year showcasing many solos as well as large ensembles. The use of the Walton Arts Center has revolutionized our concerts toward the use of stage lighting and audience comfort through the program.

Lewis Clark has conducted and organized this program for 20 years and going. He is assisted by Brett Lawson. He has seen many of his students take their skills to college as music majors in the area of performance or education. Several have achieved full scholarships as well.

620182/620192 Accents - girls (8, 9) **1 Year, 1 Unit (Fine Arts Credit)**

Students are selected by audition. Auditions including harmony, choreography, and vocal solos are held each Spring for the following year for this choir. Students will develop vocal music skills, work on sight-singing, music theory, and strive to achieve a superior choral sound at an advanced level. The choir will participate in two major concerts, compete at the Junior High Regional Choral Festival, and Audition for the Northwest Arkansas All-Region Choir. The choir also performs as a Show Choir-singing songs while doing choreography-representing Ramay throughout the community. The Accents meet for a week prior to school starting each year to begin their music as well as one day each week after school during the school year.

620183/620193 Select Girls Choir (8, 9) **1 Year, 1 Unit (Fine Arts Credit)**

This course requires teacher approval. Students will develop vocal music skills, work on sight-singing, music theory, and strive to achieve a superior choral sound. The choir will participate in two major concerts, compete at the Junior High Regional Choral Festival, and have the opportunity to audition for the Northwest Arkansas All-Region Choir. Girls in this choir may audition for the Accent Show Choir during the Spring to participate the next fall semester.

620283/620293 Select Boys Choir (8, 9) **1 Year, 1 Unit (Fine Arts Credit)**

This course requires teacher approval. Students will develop vocal music skills, work on sight-singing, music theory, and strive to achieve a superior choral sound. The choir will participate in two major concerts, compete at the Junior High Regional Choral Festival, and have the opportunity to audition for the Northwest Arkansas All-Region Choir. Boys are selected in the fall from this group to be the Accent managers.

Twelve Ramay students made the 2002-2003 Northwest Arkansas All-Region Choir.

At the Regional Choral Festival this past year, the Accents earned Superior (#1) rating and a plaque for their contest stage singing.

The Accents, Select Girls Choir, and Select Boys Choir all earned a Superior (#1) ratings for their sight-reading at the Regional Choral Festival.

ORAL COMMUNICATION (SPEECH/DRAMA)

120133 Oral Communication (9) ½ Year, ½ Unit

This is a semester class. Effective communication is the objective of this class. Students will learn what communication is and be able to identify the different types of communication. In developing an understanding of communicating, students will write different types of speeches: informative, demonstrative, and persuasive. In preparation for the speeches, students will learn how to research, write, and outline a speech. Units on debate and group discussion also will be taught. Grading will be on a letter-grade system rather than a percentage. Homework will involve completing the writing and practicing the speeches. Students enrolled in this class will take Drama during the spring semester. This course fulfills the high school graduation requirement for speech.



641033 Drama I (9) ½ Year, ½ Unit

This is a semester class. The objective of this introductory course is for students to appreciate and understand drama while participating in a variety of activities. Learning about theater history, reading and viewing plays, pantomime, improvisation, acting (monologue, duet, and/or ensemble), learning basic stage movement and techniques, and Reader's Theater are some areas of instruction. Homework will involve reading/analyzing plays and practicing/rehearsing performances. Field trips involving admission fees MAY be included in the curriculum. Due to the lack of facilities, students will not be involved in the staging of a high school play. Students taking this class will receive credit for the fine arts requirement for high school graduation. Students will enroll in Oral Communications during the spring semester. Successful completion of this course establishes a firm foundation of knowledge for Drama II.

Over half of the Ramay faculty
has a Master's Degree.

PHYSICAL EDUCATION

510183 Boys' Physical Education (8) 1 Year, 1 Unit

Students will learn the basic concepts of physical education and participate in a variety of sports activities.

510293 Boys' Physical Education (9) ½ Year, ½ Unit

Students will learn the basic concepts of physical education and participate in a variety of sports activities. This class is matched with health and meets the graduation requirement for physical education.

510283 Girls' Physical Education (8) 1 Year, 1 Unit

Students will learn the basic concepts of physical education and participate in a variety of sports activities.

510193 Girls' Physical Education (9) ½ Year, ½ Unit

Students will learn the basic concepts of physical education and participate in a variety of sports activities. This class is matched with health and meets the graduation requirement for physical education.

SCIENCE

330183 Earth Science (8) 1 Year, 1 Unit

This course focuses on the physical aspects of the earth, including the earth's geology, history, atmosphere (weather and climate), and astronomy and space. Classroom activities involving labs, field trips, and audiovisual materials enhance the learning process.

321133 Physical Science (9) 1 Year, 1 Unit

This course introduces physical laws and chemical processes, including laws of force and motion, energy, wave theory, electricity, periodic table, states of matter, chemical reaction, radioactivity, and the foundations of proper lab safety and equipment use. The course focuses on problem solving, skill development, and laboratory investigations. Some technologies used are Computer Based Labs, graphing calculators, optical light boxes, electronic laboratory equipment, and computers.

330182 Pre-AP Earth Science (8) 1 Year, 1 Unit

***RAMAY JUNIOR HIGH SCHOOL CRITERIA FOR PLACEMENT IN PRE-AP SCIENCE: 1) Willingness to complete outside classroom assignments. 2) Must have a "B" average or higher in science. 3) Teacher recommendation. 4) No schedule changes will be considered during the first quarter. 5) Special requests for students not meeting the criteria for Pre-AP placement must be made directly to the Ramay principal.**

Eighth grade Pre-Advanced Placement (AP) Earth Science class will provide students with the experiences, learning strategies, and skills base necessary for later advanced or AP science courses in high school. The course is designed for those students possibly interested in careers in science, medicine, or related fields. The learning activities focus on skill development through in-depth study of earth science related disciplines of geology, meteorology, and astronomy. The students will conduct their own ongoing original scientific research into local surface and ground water quality. They will gather, process and analyze data collected in fieldwork on local rivers and learn how to report their findings and conclusions. Each student will be expected to complete all assignments and labs, actively participate in all fieldtrips and research activities and work cooperatively with other students in problem solving activities. Although not a prerequisite for any other science course, Pre-AP Earth Science is for those students who need and want a more challenging science curriculum to provide the foundation for advanced science course work.



321232 Pre-AP Physical Science (9) 1 Year, 1 Unit

***RAMAY JUNIOR HIGH SCHOOL CRITERIA FOR PLACEMENT IN PRE-AP SCIENCE: 1) Willingness to complete outside classroom assignments. 2) Must have a "B" average or higher in science. 3) Teacher recommendation. 4) No schedule changes will be considered during the first quarter. 5) Special requests for students not meeting the criteria for Pre-AP placement must be made directly to the Ramay principal.**

The Pre-Advanced Placement (AP) Physical Science class will provide students with knowledge, experience and strategies they need in an AP program. This course reinforces crucial academic skills while developing research, problem solving and group-work methods. Students in this course will present several independent and group projects. In-depth course study will be focused in the areas of forces, energy and matter interactions. Students taking this class must desire a more challenging opportunity than the regular course. The textbook and resources used will present a higher reading and thinking skills level. A signed contract by student and parent is required for placement in this course. Pre-AP Physical Science is NOT a prerequisite for any current high school course.

SOCIAL STUDIES

440183 Social Studies/Arkansas History (8) **1 Year, 1 Unit**

This eighth grade course includes the study of Arkansas history and government with emphasis on the state, county, and local levels. A consumer oriented economics project and current events are included.

430193 American History (9) **1 Year, 1 Unit**

American History is the study of the United States to 1870. Students are expected to develop an understanding of our country's history through classroom studies including group projects, discussions of videos, and completion of individual research projects. Percentage grades will be assigned and students must pass two semesters of American History to 1870 to fulfill high school graduation requirements.

430192 Pre-AP American History (9) **1 Year, 1 Unit**

This course is designed to help students be better prepared for Honors American Studies and other Advanced Placement History courses at Fayetteville High School. Pre-AP American History will cover the same time period as regular American History. The class will be more challenging, demanding, and in depth. The textbook used will focus on higher level reading and thinking skills. There will be an emphasis on using primary sources, and on different types of writing skills used in history classes. The students will be introduced to the process of analyzing historical documents in preparation for answering document-based questions on Advanced Placement history exams. Students taking this class must desire a more challenging class and be willing to take more responsibility for their learning. There will be daily assignments. This is not a prerequisite for the 10th grade Honors American Studies class but it does prepare students for an easier transition into that class. A signed contract is required.

SPECIAL EDUCATION

Special Education classes at Ramay serve a specialized group of students who qualify by individualized testing. Students receive small group instruction based on testing results and their individual needs.

SPIRIT GROUPS

540183 Cheerleading (8) **1 Year, 1 Unit**

540193/510593

Cheerleading/P.E. (9) **1 Year, ½ Unit**

This course is for students who have made the Varsity or Junior Varsity cheer squad the previous spring. During class, the members will work on cheers, building techniques, conditioning, and performance pieces. After basketball season, the members continue to condition in order to receive P.E. credit. During second semester spirit groups will complete the P.E. curriculum to receive ½ unit.

The competition Cheerleading Squad won 1st place in the Elite School Cheer Division of the Turkey Jam Cheerleading Competition in Hot Springs. It was honored with one of only two spirit awards given to the 40 teams. It won 1st place at the Regional Competition in Bentonville, received a bid to the National Cheerleading Association Nationals in Dallas, and was named Top Team at the NCA Camp this past summer.

540283 Pom Squad (8) **1 Year, 1 Unit**

540293/510693

Pom Squad/PE (9) **1 Year, ½ Unit**

This course is for students who have made the Varsity or Junior Varsity Pom Squad the previous spring. During class, members will create and perfect routines for half-time performances, learn cheers, work on dance techniques and conditioning. After basketball season is over, the members will continue to work on conditioning in order to receive P.E. credit. During second semester spirit groups will complete the P.E. curriculum to receive ½ unit.

The Ramay Pom cheers for and supports Ramay Athletics. The Pom Squad also performs dances at half-time of football and basketball games. Both groups sell spirit ribbons and perform at pep rallies.

TECHNOLOGY EDUCATION

870183 EITE I (Exploring Industrial Technology Education (8))
½ Year, ½ Unit
(One semester, combined with Intro. to Computers for 2nd semester.)

EITE is a semester elective for 8th graders that is an action-based exploratory program combining conceptual and hands-on projects in different fields of technology. Students work with partners as they progress through activities ranging from digital imaging, photography, CO₂ powered race car, rocketry, video production, drivers ed, and computer applications such as animation and CAD. Group activities are also included. Lab fee is \$7.50.

494005 Industrial Tech Ed (9)
1 Year, 1 Unit

Industrial Technology Education is a one year, 9th grade elective that introduces students to various fields of technology including communication, construction, manufacturing, and energy/power. Students are encouraged to pursue self-directed projects and activities such as digital imaging, CAD, web page design, and wood working technology. Cooperative learning and problem solving skills are emphasized as students navigate through the technology clusters. Lab fee is \$12.

YEARBOOK

650383/650393 Yearbook Class (8, 9)
1 Year, 1 Unit

This class gives students the opportunity to be part of producing a yearbook. Students learn to draw layouts,

and use page-vision and type-vision software on IBM computers. Students also learn a vocabulary of journalistic terms. This class is limited and students are selected by teacher recommendation.



WOODLAND JUNIOR HIGH COURSE DESCRIPTIONS

AGRICULTURE

844033 Agriculture Science and Technology (9) **1 Year, 1 Unit**

This course is based on the applied and technical study of the various segments of the agriculture industry. Basic animal, plant, and soil sciences and agricultural mechanical skills are introduced. The course also deals with F.F.A. (Future Farmers of America) and agriculture careers. Students are required to keep a notebook and master a range of skills.



ART

630183/630193 Art I (8, 9) **1 Year, 1 Unit** **Fine Arts Credit for 9th graders**

This beginning course in visual art focuses on creativity, art skills, problem solving, art history, critical thinking, and the value of work. Students develop skills using various art media and methods, applying art elements and principles of design to their own creations. Art criticism and the study of artists/art styles are integrated into units that also include hands-on studio projects. There is a \$14 art fee that covers consumables. For 9th graders this course more than fulfills the fine arts high school graduation requirement.

630192 Art II (9) **1 Year, 1 Unit** **Fine Arts Credit** **Prerequisite: Art I**

Successful completion of Art I and teacher approval are required for this class. Portfolio/sketchbook review available for students not currently enrolled in art. Students will apply knowledge of the elements of art and the principles of design to more advanced art media. Independent projects are available. There is a \$14 art fee that covers the student's sketchbook and consumables. This class more than meets the fine arts requirement for high school graduation.

Woodland teachers/administrators adhere to the College Board/Advanced Placement Program premise of helping all students acquire the knowledge, concepts and skills needed to engage in a higher level of learning.

WJHS 8th grade has held the highest scores in Arkansas on the Benchmark Exams in Literacy and Mathematics in schools our size (5A) for the past two years.

ATHLETICS

Enrollment in any athletics program requires coaches' approval. Approval is based on academic record and behavior displayed in school. Arkansas Activities Association (AAA) eligibility requirements also must be met. All equipment is provided except shoes. A doctor's physical examination is required. Ninth grade students will receive ½ unit of high school physical education credit for the off-season of their sport.

Students interested in participating in soccer and/or baseball are not scheduled into athletics. These two activities are independent of the school system.

530283 Basketball – boys (8)
530293/510493 Basketball/P.E. – boys (9)
530183 Basketball – girls (8)
530193/510393 Basketball/P.E. – girls (9)

1 Year, 1 Unit

Coaches will determine who will represent our school in basketball based on grades, citizenship marks, and basketball ability. The first 2 ½ months of the program are spent in physical development and skill training for the game of basketball. During the season the athletes practice offense and defense for the upcoming game. During the post season students will focus on developing the skills of dribbling, shooting, passing, and defensive work. Students also stretch, lift weights, run, and play pickup games as they continue to develop as individuals and as a team.

Practices are designed to build confidence, promote teamwork, and develop athletic skills, discipline, responsibility, sportsmanship, and school spirit. Practices on week days are usually over by 5:30 p.m.

530283 Cross Country - boys (8)
530293/510493 Cross Country/P.E. - boys (9)
530183 Cross Country - girls (8)
530193/510393 Cross Country/P.E. - girls (9)

1 Year, 1 Unit

This program is open to boys and girls interested in learning the training and discipline necessary for competitive running, jumping, and field events. Cross country competition is the focus of the fall semester. Runners will be required to compete on Saturday according to the season's calendar. Enrollment requires the coach's approval based on academic record, behavior displayed, and ability to complete distance runs. Practice consists of runs up to 3 miles and weight training. Practices are held during 7th period, ending at 3:15 p.m. Students will compete in 6 to 8 races during September and October, held on Saturday mornings or after school. Participants must have training shoes and get a physical.

530283 Football (8)
530293/510493 Football/P.E. - boys (9)

1 Year, 1 Unit

Enrollment in football requires coaches' approval based on academic record, discipline record, behavior displayed in school, and skill in the sport.

Practices are designed to build confidence, promote teamwork, and develop athletic skills, discipline, responsibility, sportsmanship, and school spirit. Practice for football will begin two (2) weeks prior to the start of school. Once school begins practice will last until 5:30 p.m. during the school week.

530283 Track – boys (8)
530293/510493 Track/P.E. – boys (9)
530183 Track – girls (8)
530193/510393 Track/P.E. – girls (9)

1 Year, 1 Unit

This program is open to boys and girls interested in learning the training and discipline needed for competitive running sports and field events. Coaches' approval for this sport will be based on academic record, discipline record, behavior displayed in school, and skill in the sport. Track and field competition is the spring semester's goal. Athletes will learn and attempt each event. Team members will qualify according to performances.

Practices are designed to build confidence, promote teamwork, and develop athletic skills, discipline, responsibility, sportsmanship, and school spirit. Eighth graders will practice after school. Ninth graders will practice both at 7th period and after school. Practice will end by 4:30 p.m. There will be no Friday practices after school.

WJHS girls team won 1st place in XC at the Gulley Park Invitational meet.

WJHS boys team took 2nd place at the Chile Pepper XC Festival.

Eighth grade basketball boys had a perfect season 2001-2002 (18-0).

BUSINESS TECHNOLOGY

812033 Computerized Keyboarding Applications (8)
½ Year, ½ Unit
Prerequisite: Computerized Keyboarding

Computerized Keyboarding Applications is a one-semester course designed to further develop keyboarding skills. Emphasis is placed on the following: speed and accuracy, proofreading, producing mailable copy from rough draft, and the composition of various types of business communications. This is a companion course to a state-required career orientation course (see below).

812333 Computerized Business Applications (9)
1 Year, 1 Unit
Prerequisite: Computerized Keyboarding
Technology Credit

Computerized Business Applications is a two-semester course designed to prepare students with an introduction to business applications that are necessary to live and work in a technological society. Emphasis is given to hardware, concepts, and business uses of applications. The business applications covered are word processing, graphics, spreadsheet, database, and electronic mail.



CAREER ORIENTATION

850183 Career Orientation (8)
½ Year, ½ Unit
(State Required)

Students in Arkansas are required to take this course for a minimum of one semester in the eighth grade. Career Orientation follows vocational curriculum. This course is required as a hands-on, activity-based career exploration course. It provides eighth grade students the opportunity to explore the world of work in relation to their own interests and abilities.



DRAMA

See Oral Communication (Speech/Drama) on page 94.

ENGLISH

110183 English (8) 1 Year, 1 Unit

Students will use the writing process to develop detailed writing products in which they will apply the writing concepts of unity, coherence, and style. Lessons in grammar, usage, and mechanics will be incorporated into all writing projects with emphasis on sentence analysis and imitation of model sentence patterns. Students will learn to evaluate their work with the Arkansas Scoring Guide for Writing. Students will read and respond to a variety of literary forms (novels, short stories, poems, and nonfiction), many of which are self-selected. Reading comprehension and critical thinking skills are incorporated into reading lessons.

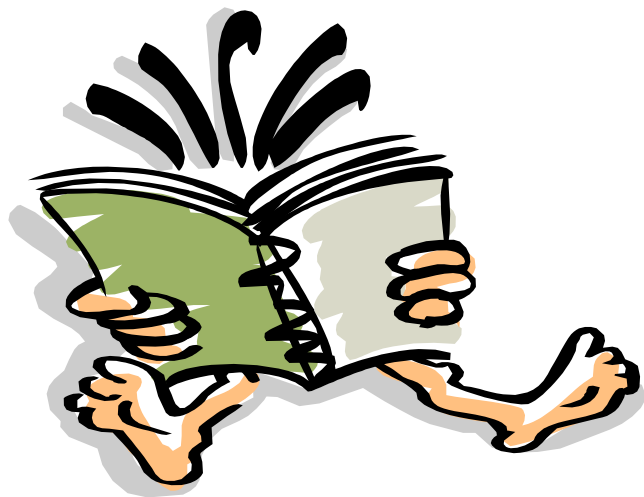

110193 English (9) 1 Year, 1 Unit

Students will be introduced to the skills that will enable them to (1) summarize, analyze, and evaluate a variety of types of literature, both fiction and nonfiction; (2) produce a variety of written products using appropriate phases of a writing process (prewriting, drafting, revising, editing, and publishing); (3) demonstrate the correct use of standard English in written products and in oral presentations; (4) explain cultural differences as they are reflected in literature and the resulting influences on language; (5) express ideas clearly and effectively in a variety of oral contexts; (6) apply active listening skills in the analysis and evaluation of spoken ideas; (7) utilize, read, or view media/technology and analyze content and concepts accurately; and (8) demonstrate research and study skills.

110192 Pre-AP English (9) 1 Year, 1 Unit

The Pre-Advanced Placement (AP) English class will provide students with the experiences and strategies they need in an AP program. Independent reading and response to literature will be integrated with material in Pre-AP American History. There will be emphasis on expository writing and outside reading. Pre-AP teachers will work with their junior high and high school colleagues in selecting appropriate materials. The coursework will be demanding. Placement will be by student choice, but the class standards and student and parent requirements must meet the criteria of the Pre-AP program. A signed contract is required. This course is NOT a prerequisite for the Honors American Studies class in the 10th grade.

FAMILY AND CONSUMER SCIENCES

820183/820193 Family and Consumer Science (8, 9) 1 Year, 1 Unit

This is a year-long laboratory course designed to provide students with the basic information and skills to function effectively as an individual and as a consumer. Emphasis is placed on wardrobe planning, garment construction, nutrition, food preparation, management, and preparing for a job search.

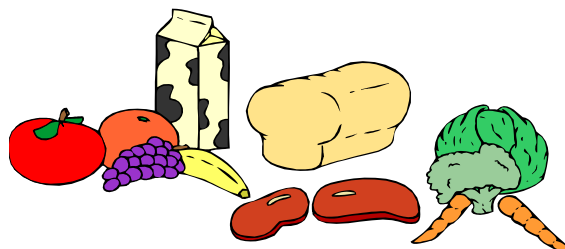

FOREIGN LANGUAGE

740183/740193 Survey of Foreign Languages (8, 9) **1 Year, 1 Unit**

This year-long survey is a course introducing students to a variety of languages. Students will learn and practice basic conversational foreign language. Students will also study the history of language, the holidays that are important to different cultures, and the famous people associated with certain languages. This course does not fulfill high school honors graduation requirements.

720233 French I (8*, 9) **1 Year, 1 Unit**

*** To take French I as an 8th grader, the student must have a “B” average or better for the 7th grade, with no grade below a “C” and a “B” for both semesters of the 7th grade Language Arts.**

In this beginning French course, students will learn to communicate in French on a variety of topics. They will be able to ask and answer questions about themselves and their possessions, friends and family, and daily activities and leisure pastimes. They will be able to express themselves accurately in a variety of situations such as making introductions, ordering a meal, shopping, socializing with peers, and making plans. To sharpen language skills, class activities include oral and written practice, individual and group study, and frequent review. Students will learn about the customs and cultures of the French-speaking countries through the use of culturally authentic videos and tapes.

720333 French II (9) **1 Year, 1 Unit** **Prerequisite:** French I

French II is a continuation of French I with emphasis on the five language skills: speaking, listening comprehension, reading, writing, and culture. Grammar study is more complex, and vocabulary is expanded to include such topics as school, professions, meals, food, shopping, entertainment, sports, health, and house and home. Emphasis continues to be on applying all grammar and vocabulary skills to conversation and to writing well-organized compositions in French. Class time is used to practice speaking and listening skills; therefore, students must assume more responsibility for mastery of text material at home. Grades are based on written or oral assignments, performance on tests, and oral interview. Thirty minutes per day for homework is expected for the average student. This course is recommended for students who have recorded grades of “C” or better in French I.

730833 German I (8*, 9) **1 Year, 1 Unit**

*** To take German I as an 8th grader, the student must have a “B” average or better for the 7th grade, with no grade below a “C” and a “B” for both semesters of the 7th grade Language Arts.**

In German I, a beginning course, students will learn to communicate accurately in German on a variety of topics. They will be able to ask and answer questions about themselves and their possessions, about friends and family, and about their daily activities and leisure pastimes. They will be able to function in German in a variety of situations such as making introductions, ordering a meal, shopping, socializing with peers, and making plans. To sharpen language skills, class activities will include oral and written practice, individual and group study, and frequent review. Students will learn about the customs and cultures of the German-speaking countries through the use of culturally authentic videos and tapes.

730933 German II (9) **1 Year, 1 Unit** **Prerequisite:** German I

German II is a continuation of the presentation of the basic grammar of the language and culture not covered in German I. In the classroom listening, speaking, reading, and writing skills are developed with the emphasis on communicative activities. Students must assume more responsibility for mastery of vocabulary than students taking German I. A minimum of twenty minutes of homework per night is required. Grades are based on test and quiz performance, homework, class participation, projects, and oral interviews. This course is recommended for students who have recorded grades of “C” or better in German I.



711283/711293 Narrative Spanish (8, 9)
1 Year, 1 Unit

This course is designed for those students who want to learn basic conversational Spanish without the emphasis on grammar studies included in Spanish I. This would be suitable for the students who request Spanish as one of their three electives in the 9th grade but who are not ready for regular Spanish I. The class will emphasize the conversational skills that students will need in the workplace, with some attention given to reading, writing, and cultural skills. The class is taught mainly by storytelling with the use of American Sign Language, songs, projects, and job-site simulations. Students will be speaking Spanish (with a limited vocabulary) almost immediately with little outside work.

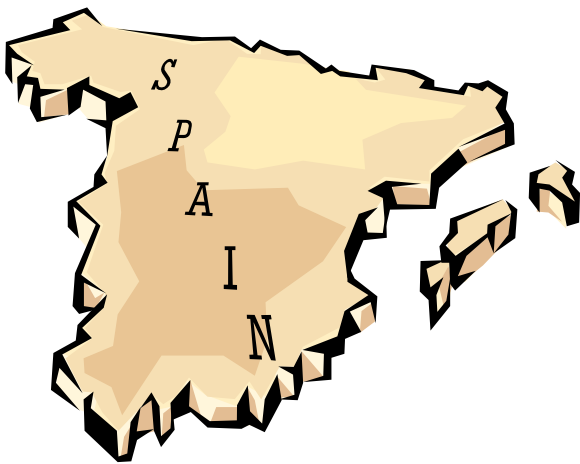

711633 Spanish I (8*, 9)
1 Year, 1 Unit
*** To take Spanish I as an 8th grader, the student must have a “B” average or better for the 7th grade, with no grade below a “C” and a “B” for both semesters of the 7th grade Language Arts.**

In this beginning Spanish course, students will learn to communicate in Spanish on a variety of topics. They will be able to ask and answer questions about themselves, friends and family, daily activities and pastimes, and possessions. They will be able to accurately express themselves in a variety of situations, such as introductions, ordering a meal, shopping, socializing with peers, and making plans. To sharpen language skills, class activities will include oral and written practice, individual and group study, and frequent review. Students will learn about the customs and cultures of the Spanish-speaking countries through the use of culturally authentic videos and tapes.

711733 Spanish II (8, 9)
1 Year, 1 Unit
Prerequisite: Spanish I

This course is a continuation of the presentation of the basic grammar and vocabulary of the language begun in Spanish I. Speaking, listening, reading, and writing skills are developed with emphasis on communicating activities. Students are expected to study vocabulary daily, complete written exercises, and prepare oral assignments. There are frequent quizzes as well as chapter tests. Discussion of Hispanic cultures emphasizing Central and South American and the Caribbean will occur throughout the year. This course is recommended for those who made a “C” or higher in Spanish I.

HEALTH

520193 Health (9)
½ Year, ½ Unit
Required for High School Graduation

This is a one-semester course required for high school graduation. The course is designed to help students achieve a high level of physical, mental, and social health. Topics covered include: total health, stress, relationships, nutrition, physical fitness, drugs, alcohol, tobacco, communicable and non-communicable diseases, consumer health, human sexuality, environmental health, and basic first aid. Emphasis will be on developing a healthy lifestyle that will benefit the student now and in the future.

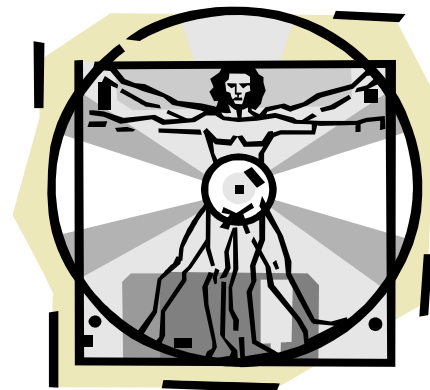

INDUSTRIAL TECHNOLOGY EDUCATION

870183 Exploring Industrial Technology Education I (EITE I) (8) 1 Year, 1 Unit

Learners are introduced to basic concepts of Exploring Industrial Technology Education (EITE). Textbook work includes material covering all four curriculum cluster areas: Communication, Construction, Production, and Transportation. Hands-on activities include drafting, rocketry, woodworking, and CO₂ racecar production. A fee of \$18 is required for consumable materials.

870292 Exploring Industrial Technology Education II (EITE II) (9) 1 Year, 1 Unit Technology Credit Prerequisite: EITE I or with teacher approval

This course is an advanced study of areas covered in EITE I. Cluster areas are more in-depth, including computers for communications, CADD (computer-aided drafting and design), power woodworking tools, drivers' education, and understanding of basic automotive concepts. Learners must have taken EITE I as a prerequisite and have instructor approval to enter EITE II. This course may be used to fulfill 1 unit of technology credit for high school graduation. A fee of \$18 is required for consumable materials.

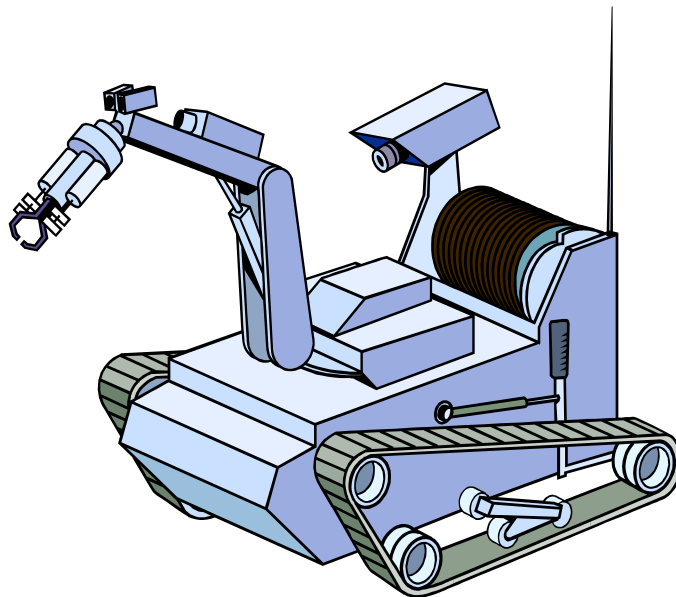

Peer Helpers serve as escorts for a day to new students to familiarize them with the school and its policies and procedures. Peer helpers also attend a fall and a spring conference to learn from experts and exchange information in the development of effective peer helping programs.

MATH

230183 Foundations of Algebra (8)

1 Year, 1 Unit

Prerequisite: Pre-algebra

This course will develop the foundation of algebraic understanding for the subsequent formal study of algebra. Students will explore relationships among quantitative variables and use numerical tables, graphs, and symbolic and verbal expressions to describe and predict the patterns of change in variables. Students will work with various representational forms and strategies (including the use of graphing calculators and other technologies) to recognize the patterns of change associated with linear, exponential, and quadratic functions and to solve common problems involving these functions. This course applies geometry, probability, statistics, and measurement concepts that develop algebraic reasoning.

230333 Algebra I (9)

1 Year, 1 Unit

Prerequisite: Foundations of Algebra

Students will develop understanding of and skills with the language of algebra; the use of properties of equality to solve linear and quadratic equations and inequalities; concepts of functions, relations, and patterns; the use of tables and graphs to represent data, make predictions, use simple matrices, use and apply linear, quadratic, and exponential functions; and polynomial operations and factoring of polynomials. Graphing calculators and other technologies will be used to develop and apply algebraic concepts to solve mathematical and real world problems.

230282 Honors Algebra I (8)

1 Year, 1 Unit

Prerequisite: Pre-algebra

This course is designed for students who have demonstrated proficiency in pre-algebra and problem solving skills. The study of Honors Algebra I requires a high level of motivation to learn and good organizational skills. Honors Algebra I is a more rigorous approach to concepts in the Algebra I curriculum which include solving equations, factoring, polynomials, graphing, rational expressions, systems of equations, and the appropriate use of the TI graphing calculator and other technologies.

Ninety-nine percent of students in Honors Algebra I scored proficient or higher on the Algebra I End of Course exam in May 2002.

Fifty-five percent of the Honors Algebra I students scored advanced.

Sixty-six percent of the school's Algebra I students scored proficient or advanced on the End of Course exam.

Ninety-three of the Honors Geometry students scored proficient or advanced on the End of Course exam in May 2002.

230782/230932 Honors Algebra II (8, 9)

1 Year, 1 Unit

Prerequisite: Honors Algebra I

This course is designed for students who have been successful in studying Honors Algebra I. Placement in this course is by teacher approval only. Honors Algebra II is a more rigorous approach to topics in the Algebra II curriculum. This course includes the structure of the real and complex number systems; coordinate geometry; relations and functions; rational and irrational expressions; matrices; linear and quadratic polynomial functions; systems of open sentences; conic sections; logarithms; and linear, quadratic, and absolute value equations and inequalities. Additional topics of matrices, graphing, complex numbers, and linear programming are included. Students planning to take AP Calculus should take this course to be sufficiently prepared.

240483/240493 Honors Geometry (8, 9)

1 Year, 1 Unit

Prerequisite: Honors Algebra I

This course is designed for students who have successfully completed Honors Algebra I. Students make conjectures based on observations using inductive reasoning. This technique is used to introduce and then reinforce the characteristics and properties of all the basic two- and three-dimensional geometric figures. Honors Geometry is a more rigorous approach to topics in the geometry curriculum. It includes critical thinking, problem solving, parallel and perpendicular lines, radicals, area and volume, and compass and straight edge construction of geometric figures. Honors Geometry is a prerequisite for Honors Algebra II. Students must maintain a 3.0 average in Honors Geometry to be recommended for placement in Honors Algebra II at the high school.

MUSIC

610183 Concert Band (8) **1 Year, 1 Unit**

Students who have achieved the minimum requirements in beginning band will be chosen to participate in the Concert Band. The Concert Band performs at various events throughout the year including the winter holiday and spring concerts. Emphasis is placed on developing individual skills while learning to perform in an ensemble setting. This group will have opportunities to compete individually and corporately at different events throughout the year.



610292 Symphonic Band (9) **1 Year, 1 Unit** **Fine Arts Credit**

Students who have achieved the minimum requirements in the Concert Band will be chosen to participate in the Symphonic Band. The band marches in the fall and performs at football games, parades, and marching contests. Students may audition for flagline, majorette, or drum major in late spring and participate in these auxiliary groups with the marching band in the fall. The Symphonic Band performs at various concerts and events throughout the year. Members will have opportunities to compete individually and corporately at different events throughout the year. This group also performs in the winter holiday and spring concerts each year.

The Woodland eighth grade Concert Band received Superior (#1) ratings in the Region One Concert Contest.

The ninth grade Symphonic Band received Superior ratings in the Regional Marching Concert Contest. In addition, they earned the Arkansas School Band and Orchestra Association Sweepstakes Award.

Numerous students make the All Region Band each year.

Many band students attend various area summer band camps and several earned honors as future captains at the UA Band Camp. These students either receive full or partial scholarships to the next year's camp.

Woodland Band Boosters continue their support by fund raising efforts to help buy instruments and send students to band camps.

620182/ 620192 Tempo Girls Choir (8, 9) **1 Year, 1 Unit** **Fine Arts Credit for 9th graders**

Students are selected by audition which includes harmony, tonal memory, choreography, and vocal solos. Auditions are held each spring for the following year. Students will develop vocal music skills, work on sight-singing and music theory, and strive to achieve a superior choral sound at an advanced level. The choir will participate in two major concerts, compete at the Junior High Regional Choral Festival, and audition for the Northwest Arkansas All-Region Choir. The choir also performs as a Show Choir – singing songs while doing choreography – representing Woodland throughout the community. The Tempos meet for a week prior to school starting each year to begin their music, as well as one day each week after school during the school year.

Thirty-one choir students made the NWA All-Region Choir.

At the Regional Choral Festival the Tempos, Select Girls, and Select Boys Choirs all earned Superior (#1) ratings in singing and sight-reading.

The Choirs performed in competitions in Dallas, Kansas City, and Branson receiving Superior ratings every time.

WJH choirs perform for the Lighting of the Ozarks, at local nursing homes, the dialysis center, and for local civic clubs.

620283/620293 Select Boys Choir (8, 9) **1 Year, 1 Unit** **Fine Arts Credit for 9th graders**

This course requires teacher approval. Students will develop vocal music skills, work on sight-singing and music theory, and strive to achieve a superior choral sound. The choir will participate in two major concerts, compete at the Junior High Regional Choral Festival, and have the opportunity to audition for the Northwest Arkansas All-Region Choir. Boys are selected in the fall from this group to be the Tempo managers.

620183/620193 Select Girls Choir (8, 9) **1 Year, 1 Unit** **Fine Arts Credit for 9th graders**

This course requires teacher approval. Students will develop vocal music skills, work on sight-singing and music theory, and strive to achieve a superior choral sound. The choir will participate in two major concerts, compete at the Junior High Regional Choral Festival, and have the opportunity to audition for the Northwest Arkansas All-Region Choir. Girls in this choir may audition for the Tempo Show Choir during the spring to participate the next fall semester.

ORAL COMMUNICATION (SPEECH/DRAMA)

120133 Oral Communication (9)
½ Year, ½ Unit
Required for High School Graduation

This course teaches students about various types of communication. Work focuses on self-discovery, communicating with others, and public speaking. Students are required to give various types of oral speeches in front of the class.

640133 Introduction to Drama (9)
½ Year, ½ Unit
Fine Arts Credit

The objective of this course is to introduce students to the various elements of drama and for students to appreciate and understand drama while participating in a variety of activities. Selected theatre history, acting, improvisations, pantomimes, characterization, stage movement, script reading and analysis, and introduction to collaborative artist will be discussed. This class meets the ½ unit fine arts graduation requirement.

PHYSICAL EDUCATION

510183 Girls' Physical Education (8)
1 Year, 1 Unit

510183 Boys' Physical Education (8)
1 Year, 1 Unit

Students will learn the basic concepts of physical education and participate in a variety of sports activities. This class is paired with health and meets the graduation requirement for physical education.

510193 Girls' Physical Education (9)
½ Year, ½ Unit

510193 Boys' Physical Education (9)
½ year, ½ Unit

Students will learn the basic concepts of physical education and participate in a variety of sports activities. This class is paired with health and meets the graduation requirement for physical education.

SCIENCE

330183 Earth Science (8)
1 Year, 1 Unit

This course provides experiences that help students both develop and apply critical thinking process skills. The experiences are provided by the use of higher level divergent questions, laboratory investigations, experiments, and problem solving activities. Emphasis is placed on skill development in order to provide students with the basic tools they need to be successful in the course. Students study topographic maps, chemistry, astronomy, weather, oceans, weathering, erosion, glaciers, rocks, minerals, earthquakes, plate tectonics, geological time, resources, and energy.

321133 Physical Science (9)
1 Year, 1 Unit

This course is a study of the composition and behavior of matter (chemistry), the laws of energy and motion (physics), and mechanics (simple machines). Math formulas and problem-solving are integral parts of the subject matter. Tests include concepts as well as knowledge of the material.

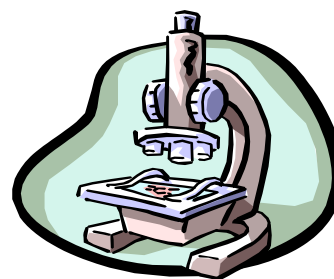

321232 Accelerated Physical Science (9)
1 Year, 1 Unit

In addition to the regular physical science curriculum, the accelerated class uses group-work, independent study, research activities, peer teaching, and advanced problem solving situations. Students in this course will perform several research projects. Laboratory investigations are often several days in length. **Completion of Algebra I is recommended before taking this class.**

SERVICE LEARNING

890193 Service Learning (9) **1 Year, 1 Unit**

This class is blocked with 9th grade English. Students must be committed to community service and believe that service is vital to the community. Students will be in training and/or service two days per week, 2 hours per day. Students will be in English 3 days per week, 2 hours per day. Students will be involved in community service training and identifying needs in the following areas: elder care, preschool care, teenage parents, and elementary tutors, plus proposals for individual student projects. In all service projects, students keep a journal of their experiences, do research on each area that they will be working in, and have a reflection time to discuss problems and achievements. Students gain an understanding of community service while being involved in a job situation.

Because class enrollment is limited, prospective students are required to obtain teacher recommendations which will include areas of leadership, responsibility, accountability, and community and school involvement. A parent or guardian signature is required along with a \$15.00 fee per semester. Because students are in the community, exemplary behavior is expected. Conduct resulting in disciplinary action may be grounds for removal from the program.

We received another \$10,000 grant for Service Learning.

SOCIAL STUDIES

440183 Social Studies/Arkansas History (8) **1 Year, 1 Unit**

This class will focus on local and state history and fundamental civic concepts and knowledge. Students will be involved in a variety of projects as they explore local and state history and government. While this course is designed around the study of Arkansas history, additional areas include economics, government, and current events.

430193 American History (9) **1 Year, 1 Unit**

Students will study American history from the Age of Exploration through the Civil War. They will learn about key events, people, and places important to our country. They will also be expected to analyze events, both in light of what was happening then and what we know today. Students will be expected to use their writing and discussion skills to defend points of view.



430192 Pre-AP American History (9) **1 Year, 1 Unit**

This course is designed to help students be prepared for Honors American Studies and other Advanced Placement History courses at Fayetteville High School. Pre-AP American History will cover the same time period as regular American History, but the textbook used will focus on higher level reading and thinking skills. There will be an emphasis on using primary sources and on different types of writing skills used in history classes. The students will be introduced to the process of analyzing historical documents in preparation for answering document-based questions on Advanced Placement history exams. Students taking this class must desire a more challenging class and be willing to take more responsibility for their learning. There will be daily assignments. A signed contract is required.

This is the recommended course to be taken before entry into the Honors American Studies block in the tenth grade. Although this is not a prerequisite for Honors American Studies. It is recommended students make an "A" or "B" in Pre-AP classes to take the Honors American Studies block.

SPIRIT GROUPS

540183 Cheerleading (8)
1 Year, 1 Unit

540193/510593 Cheerleading/P.E. (9)
1 Year, 1 Unit

This course is for students who have made the varsity or junior varsity cheer squad the previous spring. During class the girls will work on cheers, building techniques, conditioning, and performance pieces. During second semester spirit groups will complete the P.E. curriculum to receive ½ unit of P.E. credit.

540283 Pom Squad (8)
1 Year, 1 Unit

540293/510693 Pom Squad/P.E. (9)
1 Year, 1 Unit

This course is for students who have made the squad the previous spring. During class the girls will create and perfect routines for half-time performances, learn cheers, and work on dance techniques and conditioning. During second semester spirit groups will complete the P.E. curriculum to receive ½ unit of P.E. credit.

The Pom Squad competed in the NW Regional in October 2002 and placed 1st in Pom Division for the second year in a row. They also placed 3rd in the Hip-Hop Division.

Soloists placed 1st and 3rd.

Coach Agler was named the NW Region Coach of the Year 2002-2003.

STUDENT COUNCIL

000180/000190 Student Council (8, 9)
1 Year, 1 Unit

Students must apply for this class. Teacher evaluations and a written essay about why the student wants

to pursue a leadership role at Woodland are part of the selection process. This is a regularly scheduled class which receives elective credit. Students help plan various activities throughout the year and work with the administration to plan programs for the school.

September 11th, students, staff, and faculty gathered on the Woodland Junior High practice field to form a human five-pointed star to remember the tragic events of 9-11-01. A commemorative aerial photo was taken of the event.

Thirty-two food baskets were collected and assembled for this year's annual food drive: "We CAN do it!!!"

Sixty-four stockings were filled with goodies for every kindergartner at Jefferson Elementary. The Family and Consumer Science students designed and constructed all the stockings!!

The annual "Talent Show" showcased the fabulous talent of Woodland students.

WJH is the most consistent youth group to participate in United Way's "Day of Caring".

YEARBOOK

650393 Yearbook (9)
1 Year, 1 Unit

Staff members will publish the WJHS Yearbook. Finance, design, organization, writing, editing, and communication skills will be taught. A willingness to sell ads and to learn to use a computer is expected. Occasional out-of-

class time may be required to meet deadlines, sell ads, and attend school functions such as dances and athletic events. An application and approval by the teacher are required.

CLASSES FOR SPECIAL NEEDS STUDENTS

The Fayetteville Public School District provides programs for those students who have special educational needs. Placement in these programs is made after additional assessment and testing determines student need for a specific program. Programs at Woodland that fall

into this category are the Special Education Program, the Gifted/Talented Program, the ESL (English as a Second Language) Program, and academic skill building classes called Team and Team Math.

ENGLISH AS A SECOND LANGUAGE (ESL)

Only ESL students whose test scores indicate a lack of fluency in English language are known as English Language Learners (ELL). There are federal and state guidelines regarding the education of ELL students. These students not only speak English as a second language, but tests indicate that their language skills are weak in one or more of the following: speaking the language (oral), writing the language, and reading the language. Recommended placement in specific classes to address the individual student needs will be made by the LPAC members.

GIFTED & TALENTED PROGRAM

The junior high gifted and talented instructional model is a resource send-out program in which the curriculum is differentiated. Instruction is student-centered, involves student choices, and is quicker paced. Topics emphasize creativity, problem solving, and higher-level thinking skills. Mastery of a topic of study is not the sole objective. Additional objectives include a depth in

thinking, breadth and depth of activities, personal interpretation, personal challenge, and attainment of concepts at higher levels of abstraction or complexity. The curriculum is meant to be interesting as well as to provide creative experiences with challenging projects and quality production. Students are to work on developing responsibility for their own learning and growth.

SKILLS CLASSES

Team (8, 9) 1 Year, 1 Unit

Team is a class for students who need assistance with organizational and study skills so that they can better complete and turn in assignments on time and learn how to prepare for tests and quizzes. Additionally, the students will be taught test-taking strategies and techniques which will aid them in standardized testing situations. The Team teacher will help monitor homework assignments and test schedules, as well as students' grades (particularly in core subjects), in order to assist them successful completion of those courses.

Team Math (9) 1 Year, 1 Unit of Elective Credit

This course, which is a companion to the student's Algebra I class, is designed for students needing additional assistance with math skills. Instruction will include 9th grade Algebra I topics plus any math topics that students have not yet mastered. Students will learn unit labeling and unit rates as well as the use of literal equations (formulas) which are skills needed for 9th grade Physical Science as well as Algebra I. Additionally, the Team teacher will help monitor homework assignments and test schedules in order to help students be successful in their Algebra I class.

SPECIAL EDUCATION

Assistance programs are available to any student who meets the state and federal regulations for these programs. Such programs may include speech and language therapy, occupational therapy, physical therapy, and/or specialized instruction in the areas of academics

and/or emotional areas. Referrals can be made through the Counseling Office. Placement decisions will be determined by 1) recommendation of the Teacher Assistance Team which reviews all pertinent information and 2) completion of all required testing.

The Advanced Placement Program, Courses, and Examinations:

The Advanced Placement Program, sponsored by the College Board, is a program of college-level courses and examinations that provides high school students with an opportunity to earn advanced placement, college credit, or both while still in secondary school. The AP program offers students challenge, study of subjects in greater depth, accelerated learning opportunities, a sense of accomplishment, strength in a college application, development of college-level study, analytical skills, and a head start for college credit.

Advanced Placement examinations are given in May. Each college decides which AP Exam grades it will accept in return for credit and/or advanced placement. Generally, institutions accept grades of 3 and above to award credit for an equivalent course. More than 2,900 U.S. colleges and universities accept AP grades. Students seeking credit through the AP program are advised to obtain the college's AP policy in writing or refer to the institution's catalog.

Sophomore Standing: More than 1,400 institutions award a full year's credit to students presenting enough satisfactory grades on AP Exams. Each year a number of FHS students enter college with sophomore standing at the universities they attend.

Arkansas Advanced Placement Incentive Program: Arkansas is one of over twenty states that has state legislation to support the AP program and exams. The examination fee is approximately \$77. There are two ways that students may receive assistance for exam fees: (1) The State Board has established a sliding scale (based on family income) and will pay a share of the test fee; not to exceed \$65. The College Board has an additional fee reduction policy which is obtained by submitting a Fee Reduction Request Form. These requests, sent by school officials, must be submitted by April 1st. (2) Another way students may receive assistance is for taking more than two Advanced Placement exams in one year. The state will pay \$50 for each test when more than two have been taken. This program is to assist those students desiring to take multiple exams who don't qualify for sliding scale assistance but find multiple exam costs discouraging.

Information via the Internet: College Board Online at <http://www.collegeboard.org>

Northwest Arkansas Community College
Bentonville, Arkansas
Admission Policies

Admission Information

Northwest Arkansas Community college maintains an open door admission policy, which reflects the institution’s philosophy of providing educational opportunities for all citizens within its geographic area. NWACC will accept any graduate of an accredited high school, any student transferring from another college, or any person holding a General Education Development (GED) certificate. Students can also be admitted under “special” admission requirements.

- **Special Admission:** A student admitted under “Special” admission is one who is 18 years of age or older and neither graduated from high school nor completed the GED.

Admission to the college does not insure admittance to a particular course or program of study. Students may be required to take prerequisites and/or academic skills courses before enrolling in certain classes.

The college reserves the right to deny you admission, readmission or registration if you have violated the Student Code of Conduct, or when the college is unable to provide the services, courses or program needed to assist you to meet your educational objectives.

Student Conduct Code

Disciplinary measures shall be applied to any student misconduct that adversely affects the learning community’s pursuit of educational objectives, which are defined as:

- **The opportunity of all members of the learning community to pursue educational goals.**
- **The maintenance of a learning environment conducive to intellectual and educational development.**
- **The protection of college property and the safety, health and welfare of all members of the learning community.**

**University of Arkansas - Fayetteville
ADMISSION OF ENTERING FRESHMEN
FOR ACADEMIC YEAR 2003-2004**

Applicants will be reviewed on an individual basis. Grade-point average, class rank, ACT or SAT scores, a personal essay, and evidence of a commitment to success will be used to determine admissibility. New freshmen and transfer students with fewer than 24 transferable hours should have taken or be completing the following college preparatory curriculum in high school:

- English.....4 units**
- Social Studies.....3 units**
- Natural Sciences.....3 units**

(Two courses must be chosen from biology, chemistry, and physics laboratory courses. Two years of principles of technology will meet one unit of natural sciences [physics]. Two years of applied biology/chemistry will meet one unit of natural sciences [biology].)

- Mathematics..... 3 units**

(Must be chosen from algebra I, geometry, algebra II, trigonometry, pre-calculus, and calculus. Two years of applied mathematics [I & II] will meet one unit of high school algebra I.)

- Electives.....3 units**

(To be chosen from English, foreign languages, oral communications, mathematics, computer science, natural sciences, and social studies.)

- Total.....16 units**

Students who have taken the college preparatory courses listed above and who have a minimum high school grade point average of 3.0 and an ACT of 20 (or SAT of 930) or better will be admitted automatically. However, many students will be admitted on the basis of individual review of their application portfolios. The admission decision will be based on evidence of ability to graduate from the University of Arkansas.

| ENG 9 | ENG 9 | ENG 10 | ENG 10 | ENG 11 | ENG 11 | ENG 12 | ENG 12 |
|------------------|------------------|-------------|-------------|-----------------|-----------------|--------|--------|
| Math Alg. I | Math Alg. I | Math Geom. | Math Geom. | Math Alg. II | Math Alg. II | | |
| Physical Science | Physical Science | Biology | Biology | Chem Or Physics | Chem Or Physics | | |
| Social Studies | Social Studies | Amer. Hist. | Amer. Hist. | Social Studies | Social Studies | | |
| Elective | Elective | Elective | Elective | Elective | Elective | | |

Electives are to be chosen from English, foreign languages, oral communication, mathematics, computer science, natural sciences, and social studies.

College and Career Connections

What is an Associate of Applied Science (A.A.S.) Degree? These degrees are designed for students seeking to have concentrated training in a chosen career area to enter the workforce directly after graduation. An A.A.S. degree offers general education courses plus a combination of professional courses with a different emphasis depending on the career area. This degree is designed for employment purposes and it should not be assumed that the degree or the Technical Advanced Placement courses can be transferred to another institution. NTI Certificate Programs serve the training needs of students who wish to enter a recognized occupation so that they may achieve stability or advancement in employment.

The benefits of Technical Advanced Placement:

- You are not required to repeat courses in college that were mastered in high school.
- You are able to complete you're A.A.S. degree in a short period of time.
- You can enroll in more advanced courses when you begin at NWACC or NTI.
- You can save a huge amount in tuition, books, and time toward your college education – it is just as if you have already earned a scholarship!

Are there other Colleges or Technical Institutes that offer these free courses? YES! Fayetteville schools also have Technical Advanced Placement with:

- North Arkansas College in Harrison
- University of Arkansas at Ft. Smith (formally Westark College)
- Garland County Community College in Hot Springs
- Arkansas Tech University in Russellville
- Philander Smith College in Little Rock

What courses are available for Technical Advanced Placement? Some of the courses and the schools they articulate with include:

- Automotive Collision Technology – North Arkansas College and Arkansas Valley Tech. Institute
- Aviation Maintenance Technology – NWACC
- Banking and Finance Principles – NWACC
- Banking and Finance Law – NWACC
- Childcare Guidance & Management – NWACC
- Computerized Accounting I – NWACC & NTI
- Computerized Business Applications – NWACC & NTI
- Computerized Keyboarding – NWACC & NTI
- Computer Repair – NTI
- Computer Technology: Introduction – NWACC & NTI
- Drafting and Design (AutoCAD–Architecture–Engineering) – NWACCD, NTI, UA at Ft. Smith
- Medical Terminology – NWACC
- Pro-Start/Food Service Mgmt. & Lodging Mgmt. – Arkansas Tech University, Garland County Community College, Philander Smith
- Word Processing I & II – NWACC & NTI
- Law Enforcement Fundamentals & Patrol Procedures - NWACC

For more information, contact Mrs. New in the College & Career Connections office at West Campus (444-3058 ext. 104) or email jnew@fayar.net.

Youth Apprenticeship

Our Youth Apprenticeship program is required to include the following components: school-based learning, work-based learning, and connecting components. Youth Apprenticeship is:

- a planned program of training and work experiences that coordinates with school-based learning
- a program of study designed to meet the same academic content standards that the state has established for all students
- broad instruction in the classroom and workplace that exposes students to all aspects of an industry when practical
- career awareness, exploration, and counseling
- effective secondary-post secondary linkages
- initial selection of a career major no later than the beginning of eleventh grade
- workplace mentoring and instruction in general workplace competencies
- assistance for students in finding jobs and continuing their education and training.

Apprenticeship programs are available for all students including:

- academically talented
- immediately college-bound
- limited English proficient students
- students with diverse and disadvantaged backgrounds

Benefits of enrolling in an Apprenticeship Program

Students will have a high school diploma and a skill certificate recognized by employers. Many will go on to receive a college degree. Students who begin their training in high school also have the advantage of having practical work experience before going on to a post-secondary institution. The work experience allows them to absorb information in school in a much better manner.

Employers will have access to a highly trained and versatile workforce, certified and knowledgeable in all aspects of an industry.

America will have a competent, trained and highly educated workforce capable of performing at high levels and prospering in a competitive global economy.

The program areas available are as follows:

| | | |
|------------------------------|---------------------------|-------------------------------|
| Accounting | Computer Technology | Horticulture |
| Administrative Support | Culinary Arts | Marketing/Retail |
| Agriculture Technology | Dental Assistant | Medical Professions Education |
| Auto Collision Technology | Drafting | PROSTART (Culinary Arts) |
| Banking and Finance | Drama | Pre-Engineering |
| Building Trades | Early Childhood Education | Veterinary Assistant |
| Chef Preparation | Equine Studies | Welding |
| Computer Information Systems | FASST Lab | |
| Computer Repair | Food Service Management | |

Businesses who employ a Youth Apprenticeship Student also receive a tax credit. Students receive elective credit for their work experiences.

Youth Apprenticeship is a strategy for improving the transition from high school to high skill employment for young people.

For information, contact the Apprenticeship Office at 444-3083, extension 14.

Fayetteville School District

Policy No. 5127

**GRADUATION REQUIREMENTS
YEARS 2004 - 2006**

1. Any student enrolled in Fayetteville School District with at least a 2.0 cumulative GPA may receive a diploma in the 2004 - 2006 school years after completing the following requirements:

| Subject Area | Number of Units | Comments |
|------------------------|-----------------|---|
| English | 4 | No substitutions allowed |
| Math* | 3 | Algebra I, Geometry, and one higher math |
| Science | 3 | Biology, one of the physical sciences, and one science elective |
| Social Studies | 3 ½ | 2 units of American History (American History to Reconstruction and American History 1877 to present), 1 unit of World History**, ½ unit of American Government or Civics |
| Physical Education | ½ | Excluding athletics |
| Health Education | ½ | |
| Fine Arts | ½ | Art, music, drama, or Photo I |
| Oral Communications | ½ | |
| Humanities/Technology | 1 or ½ and ½ | See Appendix G-1 & G-2 |
| Electives/career major | 5 ½ | |
| Total | 22 | |

* In order to meet unconditional admission to the University of Arkansas an additional 4th year of mathematics must be taken.

** World History courses are: World History AP European, World History AMC, World History Modern Civ.

Fayetteville School District

2. Any student enrolled in Fayetteville School District with at least a 3.0 seven semester cumulative GPA may receive a diploma with **honors** in the 2004 - 2006 school years after completing the following requirements:

| Subject Area | College Prep | Tech Prep* |
|---|---|---|
| English | 4 | 4 |
| Math | 4 (Algebra I, Algebra II, and Geometry, and higher math) | 3 (Algebra I, Algebra II, and Geometry) |
| Biology | 1 | 1 |
| Chemistry or Physics | 1 | 1 |
| Science Elective | 1 | 1 |
| American History | 2 (American History to Reconstruction and American History 1877 to Present) | 2 (American History to Reconstruction and American History 1877 to Present) |
| World History** | 1 | 1 |
| American Government or Civics | ½ | ½ |
| Foreign Language | 2 (same language) | (2 recommended, not required) |
| Vocational Electives | | 6 (4 in a major field, 2 in a related field) |
| Physical Education | ½ (excluding athletics) | ½ (excluding athletics) |
| Health | ½ | ½ |
| Fine Arts | ½ (art, music, drama, or Photo I) | ½ (art, music, drama, or Photo I) |
| Oral Communications | ½ | ½ |
| Humanities/Technology | 1 or ½ and ½ | See Appendix G-1 & G-2 |
| Computer Science, English, Math, Science, Social Studies, Foreign Language, Vocational, Speech, Studio II, or Senior Studio, AP Art Studio, A Capella Choir | 2 (chosen from among the subject areas listed to the left) | |
| Electives | 3 ½ | 2 ½ |
| Total | 25 | 24 |

3. The School Board shall direct the superintendent to establish any necessary definitions and procedures by administrative regulation, consistent with this policy and any regulations of the Arkansas Department of Education.

* West Campus honor graduates must complete a senior project, and complete a vocational major of 4 units with a 3.0.
 ** World History courses are: World History AP European, World History AMC, World History Modern Civ.
 *** The Arkansas Academic Challenge Scholarship requires 4 units of math (Algebra I, Algebra II, Geometry and a high math). In addition, all classes taken in the 7th and 8th grades that received high school credit will be automatically added to the high school transcript.

FAYETTEVILLE HIGH SUMMER SCHOOL - GUIDELINES FOR SUMMER 2003

PRE-REGISTRATION

Fayetteville High Summer School for grades nine through twelve will be at East Campus and will begin on June 6th and conclude on July 2nd. Each class meets Monday through Thursday, is four hours long, and earns one semester credit (.5 unit). Summer school is for remediation or acceleration; students must have principal approval to take a class for acceleration. Remediation means that you made an “F” in the class and want to earn a higher grade. The courses we offer depend on student enrollment. You are encouraged to register as soon as possible as seats are available on a first come, first serve basis. Students may pick up their summer school schedule on June 6th at East Campus. We hope to offer the following classes:

| ENGLISH | SCIENCE | MATH | SOCIAL SCIENCE |
|--|--|--|--|
| 9 th grade Fall Semester Spring Semester | Biology Fall Semester Spring Semester | Algebra I Fall Semester Spring Semester | American History 9th Fall Semester Spring Semester |
| 10 th grade Fall Semester Spring Semester | Physical Science Fall Semester Spring Semester | Geometry Fall Semester Spring Semester | American History 10th Fall Semester Spring Semester |
| 11 th grade Fall Semester Spring Semester | | Algebra II Fall Semester Spring Semester | Ancient and Medieval Civ Fall Semester Spring Semester |
| 12 th grade Fall Semester Spring Semester | | | Modern Civilization Fall Semester Spring Semester |
| Oral Communication | | | American Government |

Students may enroll in guided study classes or Plato only if the class they need is not offered. The following guided study courses are available unless sufficient enrollment dictates a class:

- | | | |
|---------------|------------------------|----------------------|
| Art | Consumer Math | Geography |
| Economics | Ethnic Studies | Health Education |
| Speech | Environmental Sciences | Themes in Literature |
| World History | Consumer Education | |

| | | | |
|------------------------------|--------------|------------|---------------------|
| <u>CLASS SCHEDULE</u> | First Block | Mon-Thurs. | 7:30 am to 11:30 am |
| | Second Block | Mon-Thurs. | 12:00 pm to 4:00 pm |

Every effort is made to accommodate students who wish to take only one class and have a special time request of morning or afternoon. The schedule is tight, however, and we cannot always meet your time request.

TUITION

Tuition is due when students register for classes. The pre-registration fee for each class is \$110. Pre-registration ends on June 6th. Fees after June 6th are \$120 per class. Checks should be made out to Fayetteville Public Schools. If a class is not offered nor available through guided study or Plato, your tuition payment will be refunded. Tuition is non-refundable after June 9th. Out of district students pre-registration fee is \$120 and the late registration fee is \$130 per class. Late registration end on June 10th. Turn in your enrollment form and tuition payment to the main office at East Campus.

CREDITS AND GRADES

Each class brings one semester (0.5 unit). If you take a class or guided study class, you will receive a letter grade. If a student takes a class by Plato, grades will be recorded as “P” for pass or “F” for fail and will not adhere to the grade scale.

A= 100-90 B= 89-80 C=79-70 D=69-60 F=59-0

ATTENDANCE

Parents who give a work phone number and/or a home phone number will be notified each time their student is absent. State guidelines require each student to attend sixty hours in each class to receive credit. Students who miss more than 12 hours will not receive credit.

If a student is late to a class but makes it before twenty minutes has passed, the student is tardy and will make up the time during class breaks. If a student arrives to class over twenty minutes late, he or she will be counted absent for the hour. Three tardies to a class count as one hour absence.

EXPECTATIONS

- Be on time.
- Be prepared.
- Follow class instructions.
- Do not interrupt the learning process for others.
- Be considerate of others.
- Attend all 60 hours per course.
- No smoking on school property.
- Take care of school property, including parking lots.
- No violence.
- Comply with the FHS dress code established for the regular school year.
- Leave campus within thirty minutes following your last class of the day.

DISCIPLINE POLICY

Students who fail to meet summer school expectations will complete a self discipline correction plan and return the form to the summer school principal. Parents will be notified each time a discipline referral is made. An excessive number of referrals will result in the student being expelled from summer school. Serious offenses will bring expulsion upon the first occurrence. Violent acts will result in the police being notified. Parents will be notified if a student is expelled.

INDEPENDENT STUDY COURSES

Students may take these guided study courses as a **second** class during the summer school. The coursework is considered a guided study as it is teacher directed and class/seat time is required.

| | |
|------------------------|----------------------|
| Algebra | Ethnic Studies |
| Algebra II | Geography |
| Art | Geometry |
| Biology | Government |
| Consumer Math | Health Education |
| Consumer Education | Spanish I |
| Economic | Themes in Literature |
| English | World History |
| Environmental Sciences | |

First and second semester courses are available separately.

**MINIMUM CORE CURRICULUM OF HIGH SCHOOL COURSES
RECOMMENDED FOR PREPARATION FOR HIGHER EDUCATION
(This information is only good for classes graduating in 2004 - 2006)**

The recommended core of courses is designed to be a standards-based set of rigorous courses for students preparing themselves for success in college. The core curriculum consists of two components. The first component designates the core courses designed for unconditional admission to any public two-year or four-year institution of higher education in Arkansas. The second component designates the core requirements for the Arkansas Challenge Scholarship.

**Component One:
Core Curriculum for Unconditional Admission**

| | |
|------------------------|--|
| English | Four units with emphasis on writing skills, not to include courses in oral communications, journalism, drama, or debate. |
| Natural Science | Three units with laboratories; chosen from physical science, biology, chemistry, or physics. Only one unit may come from life science. |
| Mathematics | Four units, including Algebra I and II, Geometry, and an advanced math course*. It is strongly recommended that students take a math course during their senior year. |
| Social Studies | Three units, including one of American History (does not include Contemporary American History), one of World History (not to include World Cultures, World Geography, or Global Studies), and at least one-half unit of Civics or American Government (not to include courses in practical arts). |

U of A, Fayetteville also requires 3 units of electives to be chosen from English, foreign languages, oral communication, math, computer science, natural science, and social studies.

*The fourth unit of math will not necessarily be a course suitable for students planning to major in math, science, or engineering related fields. There are several courses available for this unit that will be more appropriate for a broader range of students, depending upon their career objectives. ADHE and ADE will work together in compiling a list of courses which will meet this requirement.

Component Two:

The Arkansas Academic Challenge Scholarship Program provides scholarships in the amount of \$1500 or tuition, whichever is less, to Arkansas high school students who qualify. This scholarship is currently being assessed for continuation by the Arkansas State Legislature. Consult your counselor on the status of this scholarship and the qualifications.

Eligibility Requirements for Arkansas Academic Challenge Scholarship

- Graduate from high school in Arkansas during 2004 and have a parent who is an Arkansas resident
- Take the ACT Assessment in your junior or senior year.
- Earn a 19 or better composite score on the ACT Assessment and have at least a 2.50 grade point average.

Note: If you lack any of the courses or your GPA/ACT score is a bit low **apply anyway - you could be conditionally eligible**. There is a 12-month grace period for you to make up any course while you are in college or to retake the ACT Assessment.

If you have already taken the ACT Assessment in your junior or senior year you still **must** apply to the program. The deadline to apply is August 1st the year of your graduation. **Applications will not be available until January the year of your graduation. Please do not call until January.** To apply, contact your high school counselor for an application.

Testing Information:

If you haven't taken the ACT Assessment, you must do so on one of the dates listed to be considered for the Arkansas Academic Challenge Scholarship. Pick up registration materials from your high school counselor, then complete and return them to ACT no later than the registration deadline for the test date you choose.

If you've taken the ACT Assessment more than once, the top score will be used for consideration in the program.

CALCULATING GPA

All courses are included in computing the GPA and class rank, except those classes listed as non-credit, driver's education taken during the summer, and no more than one unit of physical education. GPA and class rank are calculated at the end of the junior year and again at the end of the first semester of the senior year. Rank-in-Class is reported as follows:

- Students with above a 4.0 will be ranked #1.
- Students with 4.0 will be ranked #2.
- Students with below 4.0 will be given a ranking based on their GPA with the top students below a 4.0 ranked as #3 and so forth.

GRADUATION HONORS

Fayetteville High School recognizes three types of honor graduates. Seniors who graduate with a 4.0 GPA or above will be designated Distinguished Honor Graduates. Graduates with a 3.50-3.99 GPA will be designated High Honor Graduates. Graduates with a 3.00-3.49 GPA will be designated Honor Graduates. **NOTE:** In order to graduate with any of the three honors designations, students must meet the Honors Program criteria. See Appendix B.

DEFINITIONS

1. Unit - credit earned for passing with a "D" or better, a class which meets for two semesters.
2. Half-unit - credit earned for passing with a "D" or better, a class which meets for one semester.
3. Credit - same as "unit"
4. Semester - a school term of approximately 90 days, beginning at the start of the school year or ending at the conclusion of the school year.

NOTES & EXPLANATIONS

1. Correspondence courses from the U of A may be taken to do one of the following:
 - a) Remediation of a failing grade
 - b) To raise a grade.
 - c) For acceleration.

Correspondence courses from West Campus may be taken to do one of the following:

- a) To raise a failing grade.
- b) For acceleration with the principal's approval.

Summer School classes may be taken to do one of the following:

- a) To raise a failing grade.
- b) For acceleration with the principal's approval.

Plato courses may be taken to:

- a) Raise a failing grade, but space is limited and principal's approval is needed.
- b) Only pass/fail credit is given for Plato courses.

To raise a failing grade, the repeated course must have the same title as the failed course.

2. College credit earned at a publicly supported community college, technical college or four-year college or university by an eligible student (after completion of the 8th grade) shall be counted by the high school toward graduation, including credit earned during summer terms. Three semester hours of college credit taken by a student in grades 9-12 at a publicly supported community college, technical college or four-year college or university shall be the equivalent of one half-unit of high school credit. The student is responsible for verifying enrollment.
3. Credits earned at another school shall be counted for graduation if the other school is accredited by a state department of education or an NCA-type agency and if the credit would have counted toward graduation had it been earned here. All transfer students will be expected to meet all graduation requirements unless the principal determines that a student cannot reasonably be expected to fulfill those requirements. If the other school is not properly accredited, an individual assessment of courses/learning will be conducted to determine credit for the student.
4. A student transferring from another country shall be expected to meet all graduation requirements in order to receive a regular diploma. Where questions exist about the content or comparability of classes taken in another country, the burden of proof shall be on the student. Exchange students and other foreign students here on a temporary basis can qualify for a certificate of attendance if they are in attendance here for at least one semester.
5. Credits earned through approved homebound instruction shall count toward graduation.
6. All approved courses offered by the school shall count for graduation.
7. Students who have been home-schooled, must be in attendance at FHS at least nine consecutive months prior to their graduation.

Note: Only one unit of physical education may be counted toward the units required for graduation.

Language Arts 7-12 Path

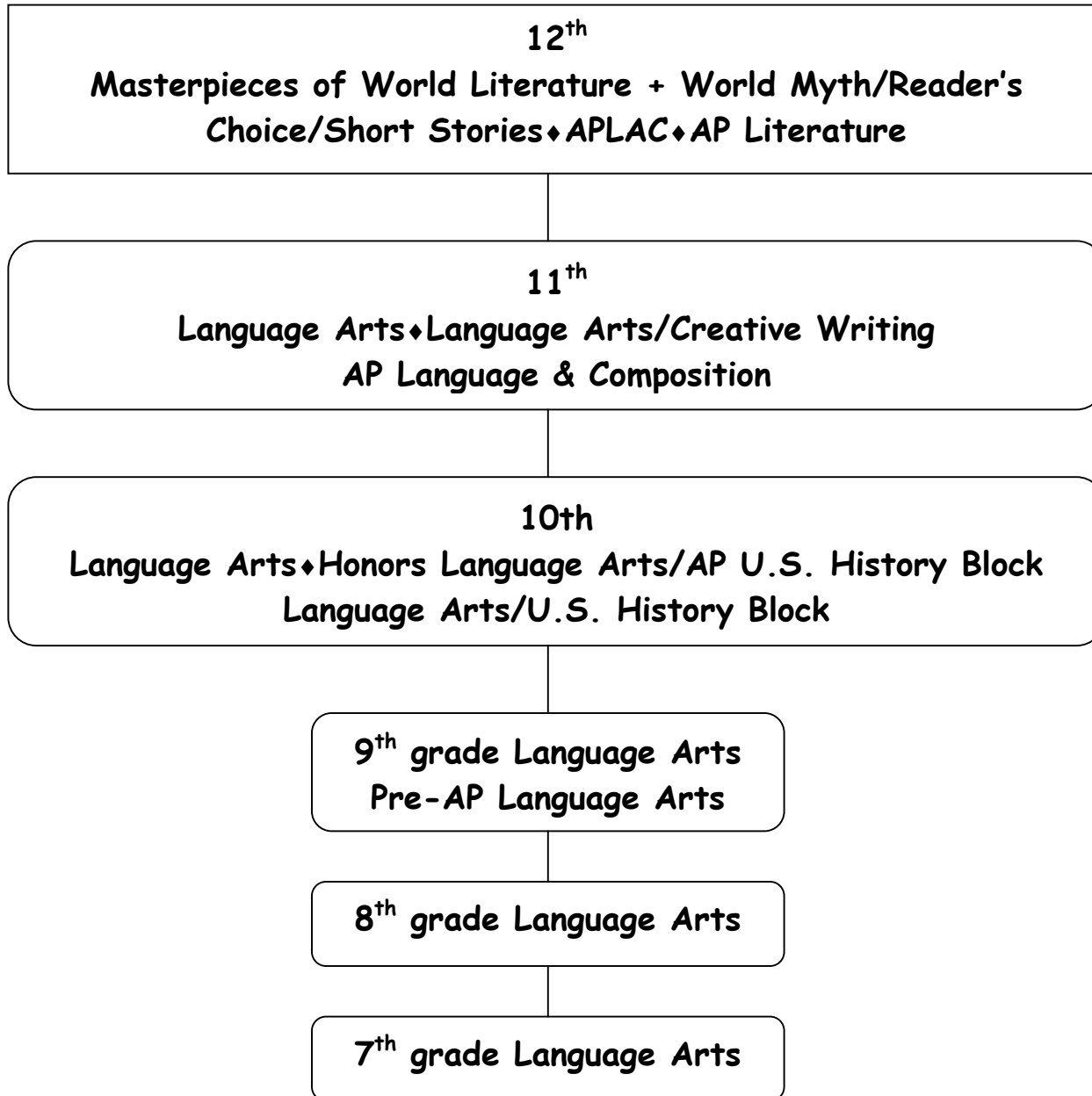

Mathematics 7-12 Path

**11th & 12th AP CalculusBC ♦ AP CalculusAB ♦ AP Statistics
College Algebra or Finite Math (Step-Ahead)
Precalculus ♦ Trig/Analysis ♦ College Prep Algebra with Trig
Algebra II ♦ Algebraic Connections**

**11th AP CalculusAB ♦ AP Statistics ♦ Precalculus ♦ Trig/Analysis
College Prep Algebra with Trig ♦ Algebra II
Algebraic Connections ♦ Geometry ♦ Applied Geometry**

**10th Trig/Analysis ♦ Honors Algebra II ♦ Algebra II ♦ Geometry
Applied Geometry ♦ Algebra I ♦ Algebraic Connections
Integrated Algebra 1A & 1B (WC)**

9th Honors Algebra II ♦ Honors Geometry ♦ Algebra I

8th Honors Geometry ♦ Honors Algebra I ♦ Foundations of Algebra

7th Honors Algebra I ♦ Integrated Prealgebra

Science 7-12 Path

**Biology II ♦ Human Anatomy/Physiology
Field Biology ♦ AP Biology
Chemistry ♦ Accelerated Chemistry ♦ AP Chemistry
Physics ♦ AP Physics B ♦ AP Physics C**

**Biology I ♦ Biology II
Human Anatomy/Physiology ♦ Field Biology
AP Biology ♦ Chemistry ♦ Accelerated Chemistry
AP Chemistry ♦ Physics ♦ AP Physics B ♦ AP Physics C**

**Biology I ♦ Accelerated Biology
Chemistry ♦ Accelerated Chemistry
Physics ♦ AP Physics B**

Physical Science (9th)

Earth Science (8th)

Life Science (7th)

Social Studies 7-12 Path

**11th & 12th Electives: Cultural Studies (12th only) ♦ AP Government & Politics
AP Psychology ♦ Geography ♦ Psychology ♦ Sociology ♦ Street Law
Western Civilization I & II ♦ Step Ahead**

**11th & 12th Required: 1 semester Government
1 year of World History-AMC ♦ World History-Modern Civilization
World History-AP European History**

**10th U.S. History to Present
AP U.S. History/Honors English Block
Am Lit/Am History Block**

**9th U.S. History to 1877
Pre-AP U.S. History**

8th Arkansas History, Government, Economics

7th Geography

Fayetteville High School Humanities Credit Options

| Course No. | Name of Course | School |
|-------------------|--------------------------|---------------------|
| 001433 | Greek and Roman Classics | East |
| 111823 | Asian Studies | East |
| 420511 | AP Euro Hist | East |
| 420713 | AMC | East |
| 420913 | Modern Civ | East |
| 421623 | Cultural Studies | East |
| 421710 | Western Civ 1003 | East |
| 421810 | Western Civ 1013 | East |
| 461411 | AP Psychology | East |
| 610233 | Music Theory | East |
| 620233 | A Capella Choir | East |
| 630331 | AP Studio Art | East |
| 630633 | Studio II | East |
| 630713 | Senior Studio | East |
| 631011 | Art History | East |
| 637633 | Teen Art Explosion | West |
| 641133 | Drama II | East |
| 641233 | Drama III | East |
| 641533 | Drama IV | East |
| 711633 | Spanish I | East/Ramay/Woodland |
| 711733 | Spanish II | East/Ramay/Woodland |
| 711833 | Spanish III | East |
| 711933 | Spanish IV | East |
| 712031 | Spanish IV AP | East |
| 712131 | Spanish Lit V AP | East |
| 720233 | French I | East/Ramay/Woodland |
| 720333 | French II | East/Ramay/Woodland |
| 720433 | French III | East |
| 730833 | German I | East/Ramay/Woodland |
| 730933 | German II | East/Ramay/Woodland |
| 731033 | German III | East |
| 731231 | German IV AP | East |

Fayetteville High School Technology Credit Options

| Course No. | Course Name | School |
|------------|-------------------------------------|---------------------|
| 001733 | FASST I | East |
| 001833 | FASST II | East |
| 001933 | FASST III | East |
| 002133 | Intro Programming in JAVA | East |
| 002231 | AP Comp Sci A in JAVA | East |
| 002331 | AP Comp Sci AB in JAVA | East |
| 492036 | Multimedia Applications I | West |
| 494005 | Industrial Tech Ed | Ramay |
| 810333 | Word Proc I | East/West |
| 810433 | Word Proc II | East/West |
| 810533 | Desktop Pub I | East/West |
| 810633 | Spreadsheet/Database | East |
| 810813 | Multimedia I | East |
| 810933 | Programming I | East |
| 811033 | Programming II | East |
| 811213 | Desktop Pub II | East/West |
| 811433 | Comp Acct I | East |
| 811513 | Comp Acct II | East |
| 812133 | Multimedia II | East |
| 812333 | Computerized Business App | East/Ramay/Woodland |
| 817833 | CT: Spreadsheet/Database | West |
| 818235 | Computer Repair-Computer Networking | East |
| 818245 | Computer Repair-Computer Operations | East |
| 818255 | Computer Repair-Diagnostics | East |
| 818433 | CT: Apprenticeship | West |
| 827533 | Child Care Guidance/Mgmt | West |
| 827733 | Child Development | West |
| 857533 | Workplace Readiness | West |
| 870292 | EITE II | Woodland |

All courses under the following headings:

| | |
|-------------------------------------|--------------------------------|
| Agriculture | Graphic Communication/Printing |
| Automotive Collision Repair | Graphic Information Systems |
| Aviation Maintenance | Horticulture |
| Building Trades | Law Enforcement |
| Cosmetology | Medical Professions |
| Drafting | Pre Engineering |
| Food Production/Service Hospitality | Specialized Certifications |